

MOD-FW2KIT300(-B)



VESA® Pattern
600 x 400mm



Max load
211lb (96kg)
per display

Modular Series Dual Pole Floor-to-Wall Kit

FOR 46" TO 90" DISPLAYS

Peerless-AV's Modular Mount Series features a full range of products to fulfill multiple requirements with a limited number of components. The universality of the components allows you to configure your own custom flat-panel display or projector mounting solution for any application. The Modular Mount Series was developed with the professional AV installer in mind with a 2" (50mm) diameter Extension Pole that can be easily cut to length on the job site, making it ideal for new projects as well as for upgrading existing installations. The MOD-FW2KIT300(-B) Floor-to-Wall Mount Kit helps eliminate guesswork, so you can create the perfect installation.

- Kit includes:
 - Floor Plate
 - Wall Plate
 - Two 118" (3m) Extension Poles
 - Single Display Mount
 - Display Stacking Clamp
 - Large Universal Adaptor
- Heavy-duty Floor Plate securely mounts to wood or concrete floors and the wall plate works with wood, concrete, cinder block or breeze block wall structures
- Universal Display Adaptor for 46" to 90" displays with VESA® mounting patterns up to 600 x 400mm
- Display can be positioned at any point along the height of the Poles
- Modular design allows additional displays to be stacked on the Dual Poles

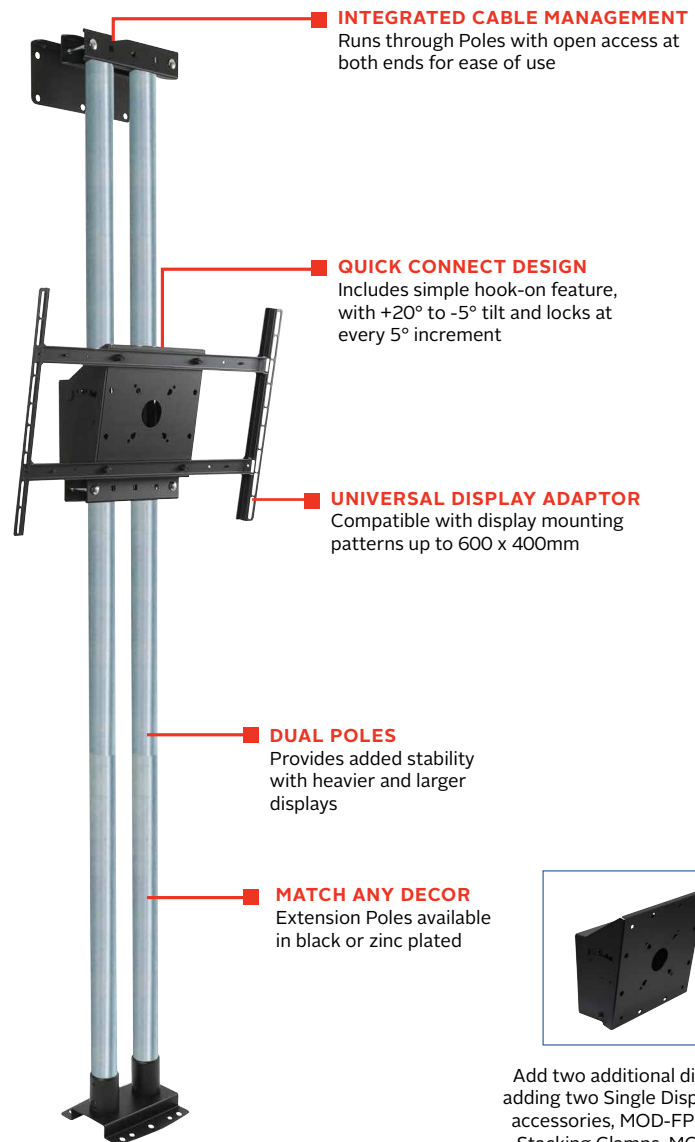

INTEGRATED CABLE MANAGEMENT
Runs through Poles with open access at both ends for ease of use

QUICK CONNECT DESIGN
Includes simple hook-on feature, with +20° to -5° tilt and locks at every 5° increment

UNIVERSAL DISPLAY ADAPTOR
Compatible with display mounting patterns up to 600 x 400mm

DUAL POLES
Provides added stability with heavier and larger displays

MATCH ANY DECOR
Extension Poles available in black or zinc plated



Add two additional displays by adding two additional Single Display Mount accessories, MOD-FPMS2, and Stacking Clamps, MOD-ASC2 (MOD-UNL2 may be required).

RoHS



✉ info@peerless-av.com

🌐 peerless-av.com

peerless-AV®
Driving Technology Through Innovation

Model Number

WARRANTY: Limited 5-year

MOD-FW2KIT300(-B) Modular Series Dual Pole Floor-to-Wall Kit for 46" to 90" Displays

Product Specifications

	DIMENSIONS (W x H x D)	PRODUCT WEIGHT	LOAD CAPACITY	FINISH	AVAILABLE COLORS
MOD-FW2KIT300(-B)	24.57" x 119.43" x 7.48" (624 x 3034 x 190mm)	51.1lb (23.2kg)	211lb (96kg) per Display For multi-screen applications the max system load is 411lb (192kg) with a maximum of three displays positioned on one side of the Poles.	Powder Coat	MOD-FW2KIT300: Black with zinc plated Poles MOD-FW2KIT300-B: Black with black Poles

Package Specifications

	PACKAGE SIZE (W x H x D)	PACKAGE SHIP WEIGHT	PACKAGE UPC CODE	PACKAGE CONTENTS	UNITS IN PACKAGE
MOD-FW2KIT300(-B)	BOX1: 38.50" x 12.25" x 8.50" (978 x 311 x 216mm) BOX 2 & 3: 120.00" x 2.50" x 2.50" (3048 x 64 x 64mm)	29.5lb (13.4kg) 14.8lb (6.7kg) each	MOD-FW2KIT300: 735029301783 MOD-FW2KIT300-B: 735029301790	MOD-CPF2, MOD-WP2, MOD-FPMS2, MOD-UNL2, MOD-ASC2, (2) MOD-P300, Mounting Hardware & Instructions	1

Accessories

MOD-ACF2: Dual Pole Cosmetic Cover
MOD-FPMS2: Dual Pole Single Display Mount
MOD-ASC2: Dual Pole Display Mount Stacking Clamp

MOD-UNL2: Large Universal Adaptor
ACC925: Security Fastener Pack

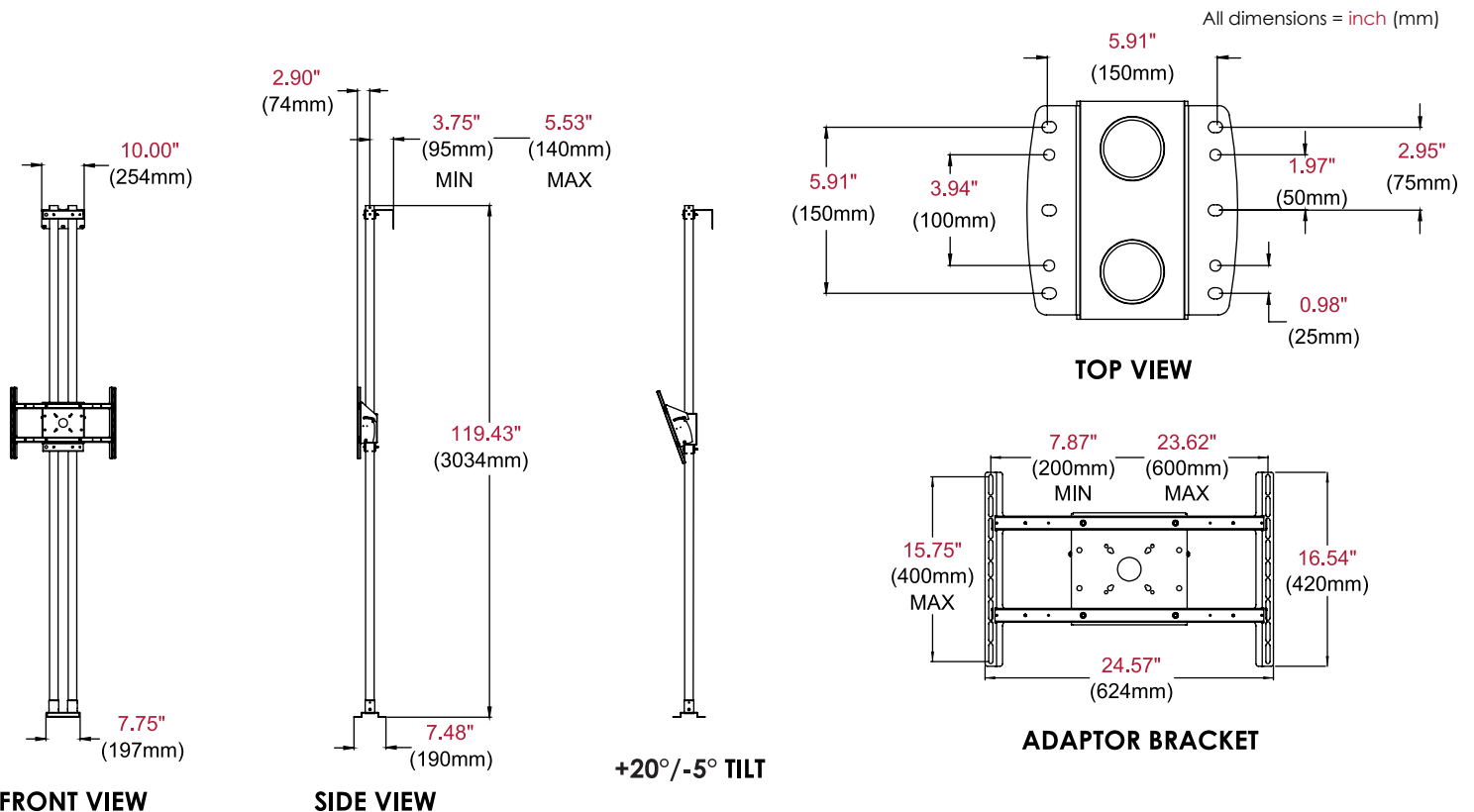

Architect Specifications

The Modular Series Dual Pole Floor-to-Wall Kit shall be a Peerless-AV model MOD-FW2KIT300(-B) and shall be located where indicated on the plans. Assembly and installation shall be done according to instructions provided by the manufacturer.

Visit peerless-av.com to see the complete line of AV solutions from Peerless-AV, including outdoor displays, wireless, kiosks, digital audio, display mounts, projector mounts, carts/stands, and a full assortment of accessories.

Peerless-AV
 2300 White Oak Circle
 Aurora, IL 60502 USA
(800) 865-2112
(630) 375-5100
Fax: (800) 359-6500

Peerless-AV EMEA
 Unit 3 Watford Interchange
 Colonial Way, Watford
 Herts, WD24 4WP
 United Kingdom
+44 (0) 1923 200100
Fax: +44 (0) 1923 200101

Peerless-AV Latin America
 Ave de las Industrias 413
 Parque Industrial Escobedo
 Escobedo, N.L.,
 Mexico 66062
+52 (81) 8384-8300
Fax: +52 (81) 8384-8360

peerless-AV®
 Driving Technology Through Innovation