

MOD-FCS2KIT300(-B)



VESA® Pattern
600 x 400mm



Max load
211lb (96kg)
per display

Modular Series Dual Pole Floor-to-Ceiling Kit

FOR 46" TO 90" DISPLAYS

Peerless-AV's Modular Mount Series features a full range of products to fulfill multiple requirements with a limited number of components. The universality of the components allows you to configure your own custom flat-panel display or projector mounting solution for any application. The Modular Mount Series was developed with the professional AV installer in mind with a 2" (50mm) diameter Extension Pole that can be easily cut to length on the job site, making it ideal for new projects as well as for upgrading existing installations. The MOD-FCS2KIT300(-B) Floor-to-Ceiling Mount Kit helps eliminate guesswork, so you can create the perfect installation.

- Kit includes:
 - Two Flat Ceiling/Floor Plates
 - Two 118" (3m) Extension Poles
 - Single Display Mount
 - Display Stacking Clamp
 - Large Universal Adaptor
- Heavy-duty Flat Floor/Ceiling Plate securely mounts to wood or concrete ceilings and floors
- Universal Display Adaptor for 46" to 90" displays with VESA® mounting patterns up to 600 x 400mm
- Display can be positioned at any point along the height of the Poles
- Modular design allows additional displays to be stacked on the Dual Poles

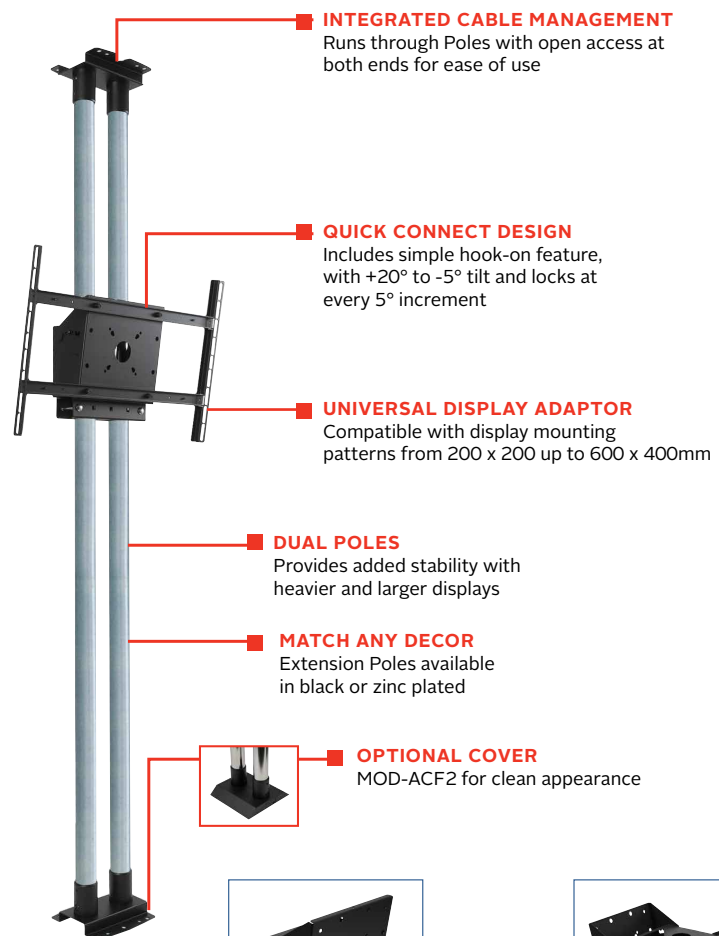

INTEGRATED CABLE MANAGEMENT

Runs through Poles with open access at both ends for ease of use

QUICK CONNECT DESIGN

Includes simple hook-on feature, with +20° to -5° tilt and locks at every 5° increment

UNIVERSAL DISPLAY ADAPTOR

Compatible with display mounting patterns from 200 x 200 up to 600 x 400mm

DUAL POLES

Provides added stability with heavier and larger displays

MATCH ANY DECOR

Extension Poles available in black or zinc plated

OPTIONAL COVER

MOD-ACF2 for clean appearance

Add two additional displays by adding two Single Display Mount accessories, MOD-FPMS2, and Stacking Clamps, MOD-ASC2 (MOD-UNL2 may be required).

Install up to six displays in a back-to-back configuration using Dual Pole Back-to-Back Display Mount accessories, MOD-FPMD2, and Stacking Clamps, MOD-ASC2 (MOD-UNL2 may be required).



MOD-FCS2KIT300(-B) Modular Series Dual Pole Floor-to-Ceiling Kit for 46" to 90" Displays

Product Specifications

	DIMENSIONS (W x H x D)	PRODUCT WEIGHT	LOAD CAPACITY	FINISH	AVAILABLE COLORS
MOD-FCS2KIT300(-B)	24.57" x 120.89" x 7.48" (624 x 3071 x 190mm)	51.1lb (23.2kg)	211lb (96kg) per Display For multi-screen applications, the max system load is 411lb (192kg) with a maximum of three displays positioned on one side of the Poles or six displays back to back.	Powder Coat	MOD-FCS2KIT300: Black with zinc plated Poles MOD-FCS2KIT300-B: Black with black Poles

Package Specifications

	PACKAGE SIZE (W x H x D)	PACKAGE SHIP WEIGHT	PACKAGE UPC CODE	PACKAGE CONTENTS	UNITS IN PACKAGE
MOD-FCS2KIT300(-B)	BOX1: 38.50" x 12.25" x 8.50" (978 x 311 x 216mm)	27.5lb (12.5kg)	MOD-FCS2KIT300: 735029301769	(2) MOD-CPF2, MOD-FPMS2, MOD-UNL2, MOD-ASC2,	1
	BOX 2 & 3: 120.00" x 2.50" x 2.50" (3048 x 64 x 64mm)	14.8lb (6.7kg) each	MOD-FCS2KIT300-B: 735029301776	(2) MOD-P300, Mounting Hardware & Instructions	

Accessories

- MOD-ACF2:** Dual Pole Cosmetic Cover
- MOD-FPMS2:** Dual Pole Single Display Mount
- MOD-FPMD2:** Dual Pole Back-to-Back Display Mount
- MOD-ASC2:** Dual Pole Display Mount Stacking Clamp
- MOD-UNL2:** Large Universal Adaptor
- ACC925:** Security Fastener Pack

All dimensions = inch (mm)

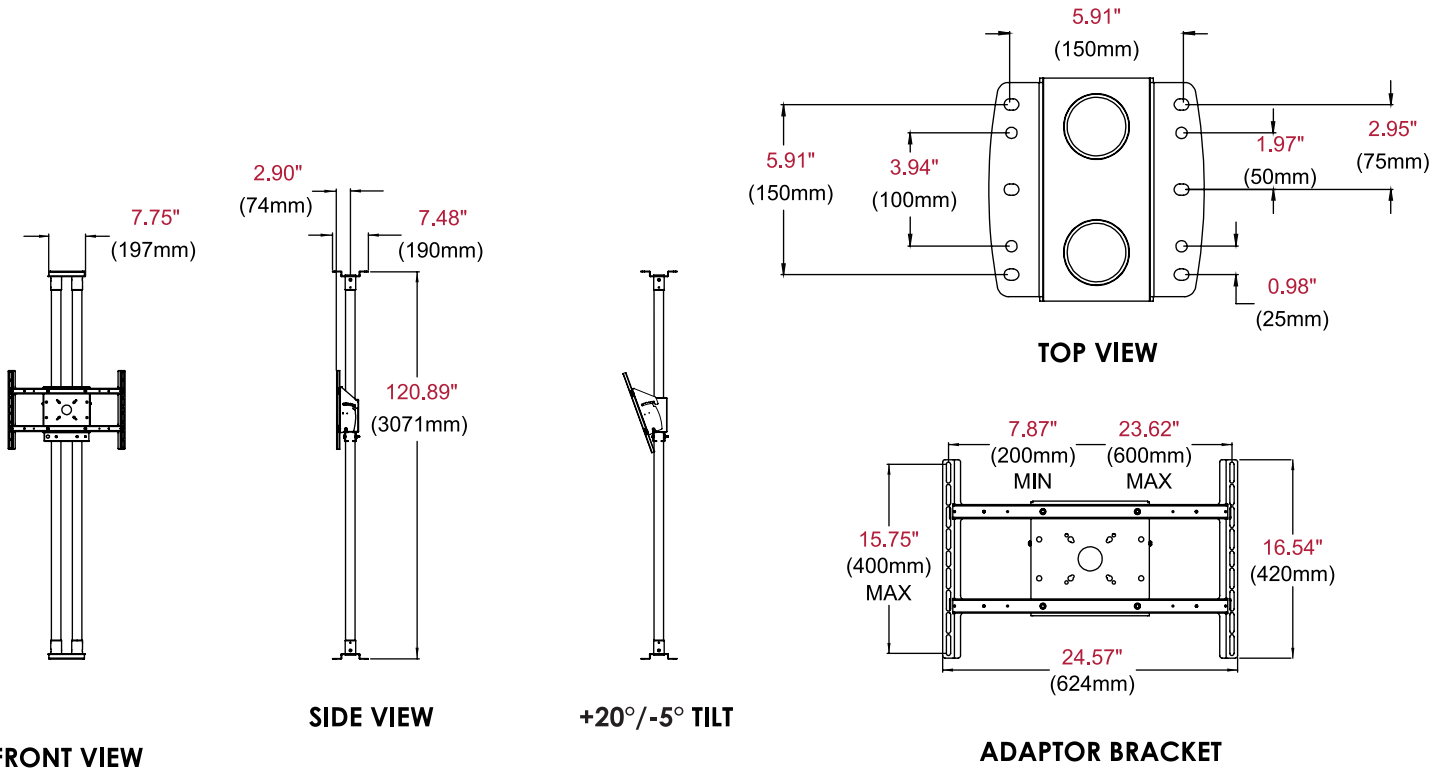

Architect Specifications

The Modular Series Dual Pole Floor-to-Ceiling Kit shall be a Peerless-AV model MOD-FCS2KIT300(-B) and shall be located where indicated on the plans. Assembly and installation shall be done according to instructions provided by the manufacturer.

Visit peerless-av.com to see the complete line of AV solutions from Peerless-AV, including outdoor displays, wireless, kiosks, digital audio, display mounts, projector mounts, carts/stands, and a full assortment of accessories.

Peerless-AV
2300 White Oak Circle
Aurora, IL 60502 USA

(800) 865-2112
(630) 375-5100
Fax: (800) 359-6500

Peerless-AV EMEA
Unit 3 Watford Interchange
Colonial Way, Watford
Herts, WD24 4WP
United Kingdom
+44 (0) 1923 200100
Fax: +44 (0) 1923 200101

Peerless-AV Latin America
Ave de las Industrias 413
Parque Industrial Escobedo
Escobedo, N.L.,
Mexico 66062
+52 (81) 8384-8300
Fax: +52 (81) 8384-8360

