

MOD-AWM2



Display size
46"-90"*



Max load
211lb (96kg)*
per display

Modular Series Dual-Pole Wall Mount Interface

FOR 46" TO 90" DISPLAYS*

Peerless-AV's Modular Mount Series features a full range of products to fulfill multiple requirements with a limited number of components. The universality of the components allows you to configure your own perfect custom flat-panel display or projector mounting solution for any application. The Modular Mount Series was developed with the professional AV installer in mind with a 2" (50mm) diameter support pole that can be easily cut to length on the job site making it ideal for new projects as well as for upgrading existing installations. The MOD-AWM2 provides modular support for a range of video wall mount plates, including standard flat and tilt.

The universal design of the MOD-AWM2 allows you to configure your desired application just the way you want it, making a perfect installation possible.



Additional Features

- ✓ Provides compatibility with Peerless-AV Flat, Tilt and Video Wall mounts onto the Modular Series Dual Pole configurations
- ✓ When used as a display mount, displays can be mounted in portrait or landscape orientation
- ✓ VESA® 200, 300 & 400mm mounting holes for 46" to 90" displays when used as a display mount*
- ✓ 211lb (96kg) max weight capacity when used as a display mount*

*Reference mount specifications when used with optional Flat, Tilt or Video Wall Mounts



VERSATILE POSITION
Can be clamped at any point along pole length for ideal display placement

DUAL-POLE WALL MOUNT INTERFACE
Provides compatibility with Peerless-AV Flat, Tilt and Video Wall mounts onto the Modular Series Dual Pole configurations



2x2 LANDSCAPE VIDEO WALL
Shown in Modular Series Dual Pole
Free Standing configuration
(SmartMount® Full Service Video Wall Mount, DS-VW765-LAND, required)

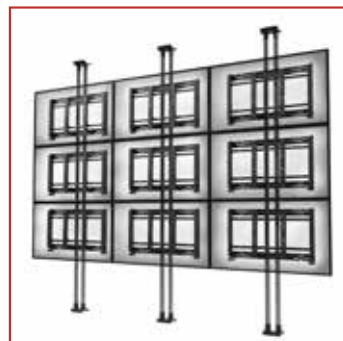

3x3 LANDSCAPE VIDEO WALL
Shown in Modular Series Dual Pole
Floor-to-Ceiling configuration
(SmartMount® Full Service Video Wall Mount with Quick Release, DS-VW765-LQR, required)



3x2 PORTRAIT VIDEO WALL
Shown in Modular Series Dual Pole
Floor-to-Wall configuration
(SmartMount® Full Service Video Wall Mount with Quick Release, DS-VW765-PQR, required)



MOD-AWM2 Modular Series Dual-Pole Wall Mount Interface for 46" to 90" Displays*

Product Specifications

*Reference mount specifications when used with optional Flat, Tilt or Video Wall Mounts

	DIMENSIONS (W x H x D)	PRODUCT WEIGHT	LOAD CAPACITY	FINISH	AVAILABLE COLORS
MOD-AWM2	18.00" x 2.00" x 3.39" (457 x 51 x 86mm)	6.5lb (3.0kg)	211lb (96kg)* per display	Powder Coat	Black

Package Specifications

	PACKAGE SIZE (W x H x D)	PACKAGE SHIP WEIGHT	PACKAGE UPC CODE	PACKAGE CONTENTS	UNITS IN PACKAGE
MOD-AWM2	25.00" x 4.25" x 4.38" (635 x 108 x 111mm)	7.0lb (3.2kg)	735029301097	MOD-AWM2, mounting hardware & instructions	1

Accessories

- MOD-CPI2:** Dual Pole I-Beam Ceiling Plate
- MOD-WP2:** Dual Pole Wall Plate
- MOD-FPP2:** Dual Pole Free Standing Floor Plate
- MOD-CPF2:** Dual Pole Square Ceiling/Floor Plate, Flat
- MOD-ACF2:** Dual Pole Cosmetic Cover
- ACC925:** Security Fastener Pack
- MOD-P100/150/200/300(-B):** Extension Poles
- SF640 to SF680 models:** SmartMount® Flat Wall Mounts
- ST640 to ST680 models:** SmartMount® Tilt Wall mounts

- DS-VW765-LQR:** SmartMount® Full Service Video Wall Mount with Quick Release - Landscape for 46" to 65" Displays
- DS-VW765-PQR:** SmartMount® Full Service Video Wall Mount with Quick Release - Portrait For 42" to 65" Displays
- DS-VW765-LAND:** SmartMount® Full Service Video Wall Mount - Landscape For 40" to 65" Displays
- DS-VW765-POR:** SmartMount® Full Service Video Wall Mount - Portrait for 42" to 65" Displays

All dimensions = inch (mm)

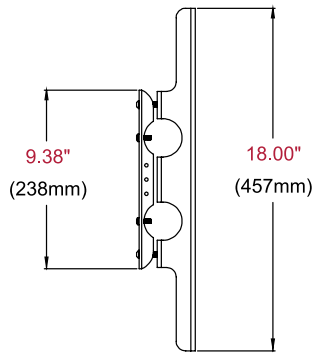

TOP VIEW

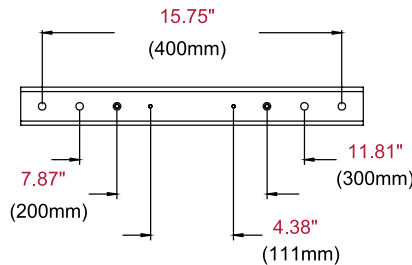

FRONT VIEW

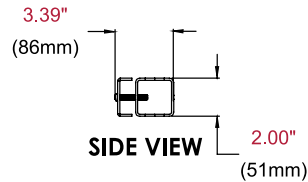

SIDE VIEW

Architect Specifications

The Modular Series Dual-Pole Wall Mount Interface shall be a Peerless-AV model MOD-AWM2 and shall be located where indicated on the plans. Assembly and installation shall be done according to instructions provided by the manufacturer.

Visit peerless-av.com to see the complete line of AV solutions from Peerless-AV, including outdoor displays, wireless, kiosks, digital audio, display mounts, projector mounts, carts/stands, and a full assortment of accessories.

Peerless-AV
2300 White Oak Circle
Aurora, IL 60502 USA
(800) 865-2112
(630) 375-5100
Fax: (800) 359-6500

Peerless-AV Europe
Unit 3 Watford Interchange
Colonial Way, Watford
Herts, WD24 4WP
United Kingdom
+44 (0) 1923 200100
Fax: +44 (0) 1923 200101

Peerless-AV de México
Ave de las Industrias 413
Parque Industrial Escobedo
Escobedo, N.L.,
Mexico 66050
+52 (81) 8384-8300
Fax: +52 (81) 8384-8360

