

AND-STROBE-KIT-1  
includes AND-PIA-2

### OVERVIEW

The AND Strobe Kit (AND-STROBE-KIT-1) provides an additional mode of emergency notification or alert messaging when connected to an AND IP endpoint. Contact Tech Support if you plan to connect the strobe to the IPSIGNAL-RWB or IPCDS-RWB-U, this requires the AND-PIA-2D, which will be provided at no additional cost. [tech@anetd.com](mailto:tech@anetd.com) or 847-463-2237

### ANALOG INTEGRATION



Activate strobe by connecting to contact closure, call button, existing security system, etc.

### SOFTWARE



Diagnostic software included  
Compatible with third-party software, including InformaCast, Revolution, and Cisco CallManager

### SIP INTEGRATION



SIP ring detection alert

### SOLUTIONS

- Code alerts
- Emergency notification
- Security monitoring

### ADDITIONAL FEATURES

- Built-in web server
- Full multicast and broadcast support
- Operates by connecting the Peripheral Interface Adapter (included) to an AND IP display device

### ACCESSORIES & MOUNTING

- Standard junction box required for mounting
- Color lenses available from System Sensor
  - Yellow, Green, Red, Blue

### COMPATIBLE DEVICES

#### AND-STROBE-KIT-1

IPSWDHD-MW  
IPCSHD-MB  
IPSWD-RWB  
IPCSS-RWB  
IPCSS-RWB-MB  
IPCSL-RWB

Contact Tech Support for:  
IPSIGNAL-RWB  
IPCDS-RWB-U

[tech@anetd.com](mailto:tech@anetd.com)  
847-463-2237

## SOFTWARE

The AND-STROBE-KIT-1 integrates easily with third-party mass notification software, as well as SIP and VoIP phone systems, enabling a facility to take advantage of all the device capabilities. The device also comes with diagnostic software (compatible to run alongside third-party software), and an on-board web server interface, both which provide the ability to monitor and troubleshoot the ANetD devices on the network.

### Third-Party Software

- InformaCast (Singlewire)
- Revolution (Syn-Apps)
- IPSession (IPCelerate)
- MessageNet Systems
- BellComander (Acro Vista)
- And more!

### VoIP Phone Systems

- Cisco CallManager
- Mitel
- Avaya
- 3CX
- Polycom
- And more!

### IPClockWise

- Diagnostic tool included with device purchase
- Complements investment in third-party software
- Developed and supported by Advanced Network Devices

## DIMENSIONS

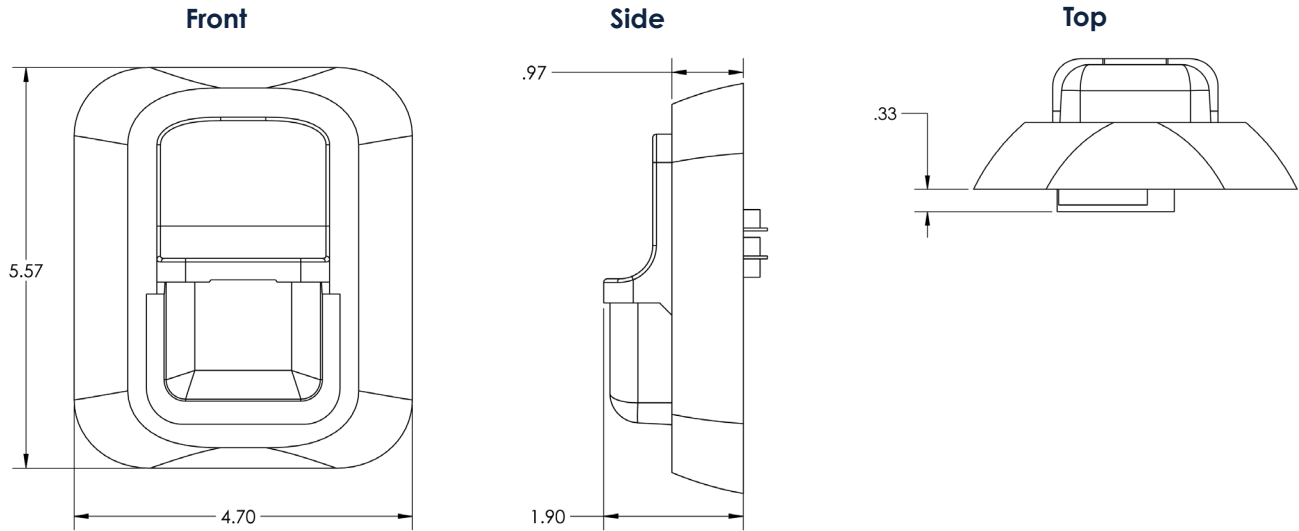

SPECIFICATIONS	STROBE
ETHERNET I/F	10/100 Mbps
FLASH RATE	1 flash per second
LUMINOUS INTENSITY	15/75 Candela
POWER	Powered by connected ANetD device
OPERATING TEMPERATURE	0° TO 49° C (32° TO 120° F)
HUMIDITY RANGE	10 TO 93% Non-condensing
DIMENSIONS	4.65" W x 5" H x 2.75"D
WEIGHT	2 lbs (0.91 kg)
WARRANTY	2 Year Limited

SPECIFICATIONS	AND-PIA-2 and AND-PIA-2D
CONNECTION TO STROBE	18-22 AWG stranded or solid core wire pair
SIGNAL COMBINATIONS Available via 2 "Poke-Home" Connectors	Audio Line In Audio Line Out 2 General Purpose Inputs 1 General Purpose Output Relay (N.O. or N.C.; dry or 12V or 15V DC, 1A max)
POWER	Powered by connected ANetD device
OPERATING TEMPERATURE	0° TO 49° C (32° TO 120° F)
HUMIDITY RANGE	10 to 93% Non-condensing
DIMENSIONS	AND-PIA-2: 2.26" W x 0.79" H x 1.72" L AND-PIA-2D: 2.26" W x 1.15"H x 1.72"L
WEIGHT	0.6 oz
WARRANTY	2 Year Limited

Due to continual product development, specifications are subject to change without notice.

