

FPZ-600



Mounting Pattern
100, 200 x 100,
or 200 x 200mm



Max Load
200lb (90.7kg)
per display

Flat Panel Floor Stand

FOR UP TO 75" DISPLAYS

Peerless-AV's Flat Panel Floor Stand provides a safe and secure solution for displaying digital content in public areas, such as conference rooms, lobbies or convention centers. The versatility and functionality of this solidly engineered stand enables single display, two displays back-to-back, two displays in portrait orientation, or even four displays in either landscape or portrait orientation (may require additional accessory). Integrated security fasteners lock the displays in place, virtually eliminating theft, while internal cable management completely hides all wires and cables enabling a clean, professional finish.

- VESA® 100, 200 x 100 and 200 x 200mm compliant
- Supports additional VESA® patterns with PLP display adaptor (sold separately)
- Fits single or back-to-back displays (up to four with additional dual-display cartridge)
- Portrait or landscape display orientation
- Height adjustable on 72" (1829mm) poles

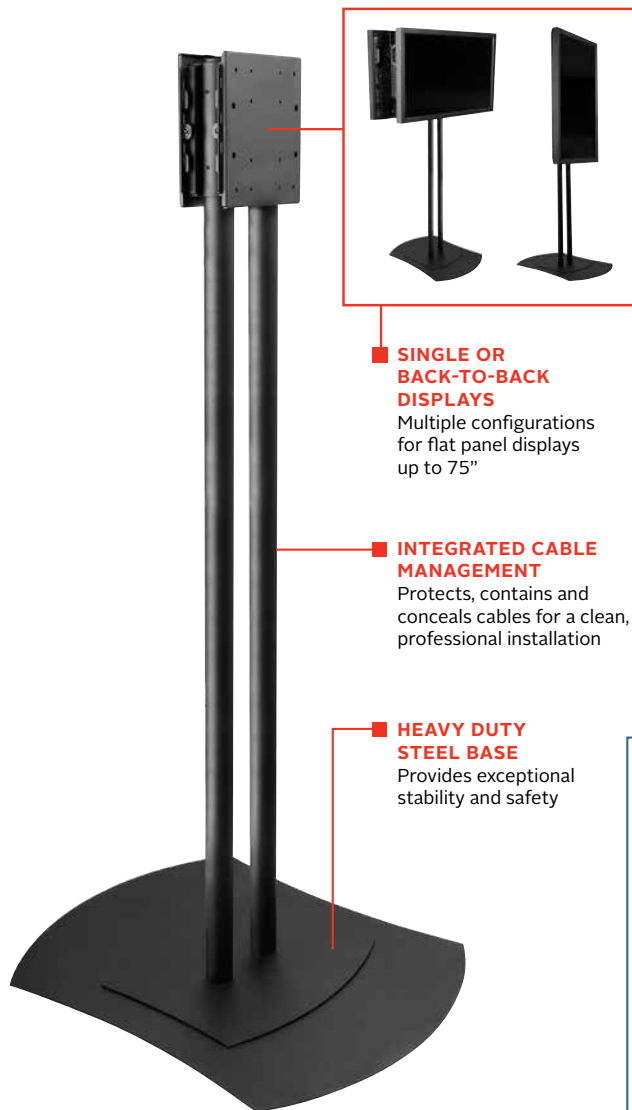

■ **SINGLE OR BACK-TO-BACK DISPLAYS**

Multiple configurations for flat panel displays up to 75"

■ **INTEGRATED CABLE MANAGEMENT**

Protects, contains and conceals cables for a clean, professional installation

■ **HEAVY DUTY STEEL BASE**

Provides exceptional stability and safety

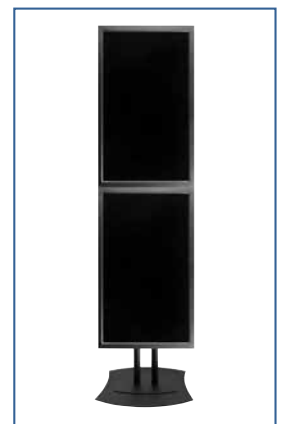

Portrait Dual-Displays
(Requires ACC604 Adaptor)



RoHS
2002/95/EC

✉ info@peerless-av.com

🌐 peerless-av.com

peerless-AV®
Driving Technology Through Innovation

FPZ-600 Flat Panel Floor Stand for up to 75" Displays

Product Specifications

	DIMENSIONS (W X H X D)	PRODUCT WEIGHT	LOAD CAPACITY	FINISH	AVAILABLE COLORS
FPZ-600	28.91" x 72.33" x 36.00" (734 x 1837 x 914mm)	108.2lb (49kg)	200lb (90.7kg) Per Display, Up to 4 Displays	Powder Coat	Black

Package Specifications

	PACKAGE SIZE (W x H x D)	PACKAGE SHIP WEIGHT	PACKAGE UPC CODE	PACKAGE CONTENTS	UNITS IN PACKAGE
FPZ-600	Box 1: 37.00" x 30.25" x 9.50" (940 x 768 x 241mm) Box 2 and 3: 73.00" x 4.13" x 4.13" (1854 x 105 x 105mm)	Box 1: 87lb (39.5kg) Box 2 and 3: 19.0lb (8.6kg)	735029242604	Floor Base, 2 Columns, Dual-Display Cartridge, 2 VESA® Display Adaptor Brackets & Mounting Hardware	1

Accessories

- ACC604:** Dual-Display Cartridge
- ACC340:** Media Player Shelf
- ACC325:** Accessory Shelf
- ACC-DS-VW2X2:** Video Wall Conversion Kit
- ACC-UCM:** Universal AV Component Mount
- MIS-UNL:** Universal Display Adaptor for 32" to 75" Displays
- PLP-V models:** Dedicated Adaptor Plates
- RMI2C:** Rotational Mount Interface

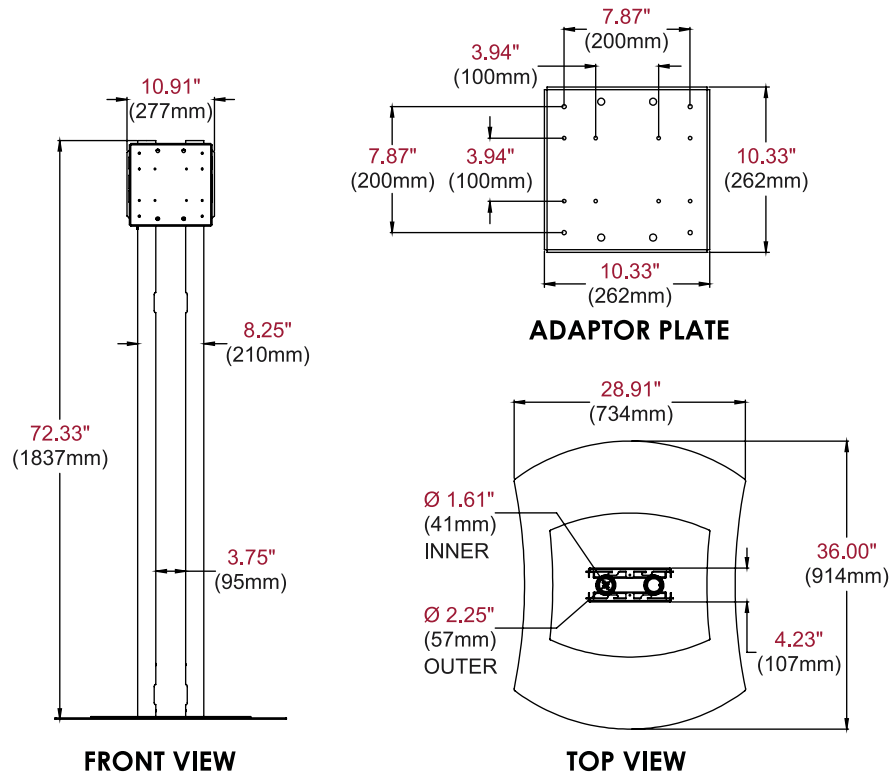

All dimensions = inch (mm)

Architect Specifications

The Flat Panel Floor Stand shall be a Peerless-AV model FPZ-600 and shall be located where indicated on the plans. Assembly and installation shall be done according to instructions provided by the manufacturer.

Visit peerless-av.com to see the complete line of AV solutions from Peerless-AV, including outdoor displays, kiosks, digital audio, display mounts, projector mounts, carts/stands, and a full assortment of accessories.

Peerless-AV
2300 White Oak Circle
Aurora, IL 60502 USA
(800) 865-2112
(630) 375-5100
Fax: (800) 359-6500

Peerless-AV EMEA
Unit 3 Watford Interchange
Colonial Way, Watford
Herts, WD24 4WP
United Kingdom
+44 (0) 1923 200100
Fax: +44 (0) 1923 200101

Peerless-AV Latin America
Av. de las Industrias 413
Parque Industrial Escobedo
General Escobedo, N.L.,
México, 66062
+52 (81) 8384-8300
Fax: +52 (81) 8384-8360

