



## ELECTRIC LIFT WALL STAND

Designed for Microsoft Surface Hub 2S 50"

FPS2W/EL/MS/GG



Take control of creative, presentation and collaboration work spaces. Salamander's beautiful and highly functional FPS Series Stands offer superior ergonomics complimenting any touch screen display with improved productivity, unrivaled flexibility and lifetime value.

Electric lift, wall stand features an accessible, compact, low profile design that conceals all equipment and cabling.

- Wall stand for interactive display / touchscreen panel
- Compatible with most large displays including 86" Screens and Microsoft Surface Hub 2S, see VESA pattern and weight limits.
- Motorized electric lift and wired remote control
- Ergonomic design. Adjustable height positioning provides best possible ergonomics and viewing.
- Fully concealed cable management allows clean and uncluttered installation
- Range of travel, Center of screen: Min - 34.01" (863.8 mm) and Max 59.6" (1513.8 mm)
- Interior equipment mounting area for electronic components, peripherals and accessories.
- Adjustable component mounting brackets & velcro straps
- Durable construction. Made in USA of powder coated steel, Linak Motor components, Powder coated and/or veneered MDF panels
- Limited lifetime warranty



© 2020 Microsoft. Microsoft, the Microsoft logo, Microsoft Surface, Surface, and the Microsoft Surface logo are trademarks of the Microsoft group of companies. All other trademarks are the property of their respective owners.





# ELECTRIC LIFT WALL STAND

Designed for Microsoft Surface Hub 2S 50"

FPS2W/EL/MS/GG

FRONT

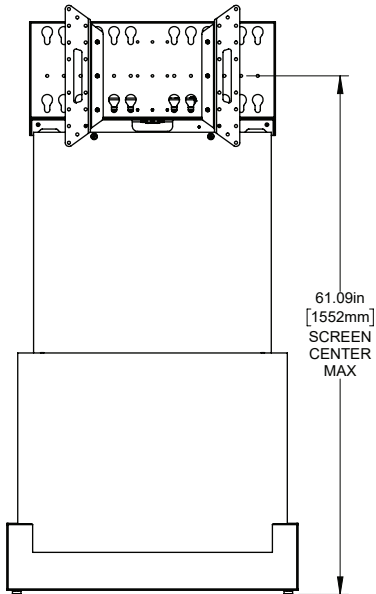

RIGHT

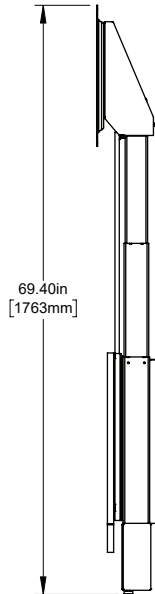

REAR

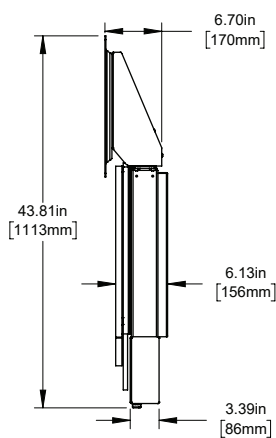
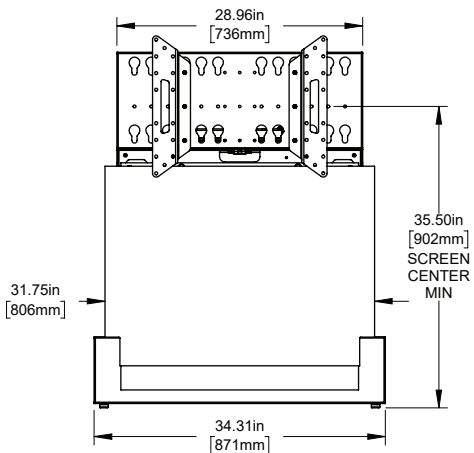
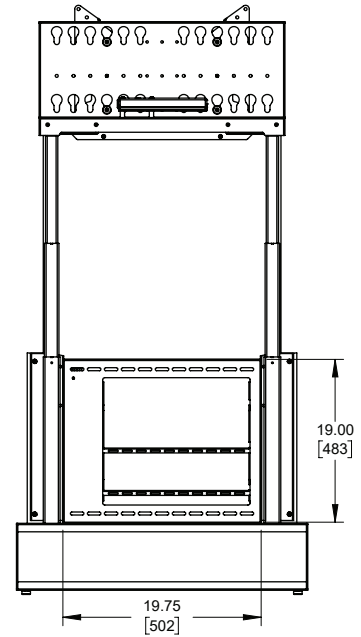

**\*WALL FASTENING**

Fasteners not included, select based on type of wall. Be sure wall structure is sufficient to handle load. Accommodates 5/16 inch (8 mm) fasteners.





# ELECTRIC LIFT WALL STAND

Designed for Microsoft Surface Hub 2S 50"

FPS2W/EL/MS/GG

PRODUCT SPECIFICATIONS	Metric (mm)	US/Imperial Inches	SHIPPING DIMENSIONS		
Length	871.5	34.31	1,213 mm	47.75 inch	
Overall Height Range	1128.8 - 1778.8	44.44 - 70.03	997 mm	39.25 inch	
Center of Screen Range of Travel	863.8 - 1513.8	34.01 - 59.6			
Depth	204	8.03	197 mm	7.75 inch	
Weight	52.16 kg	115 lbs	59 kg	130 lbs	
<b>Max Load Capacity</b>	<b>79.38 kg</b>	<b>175 lbs</b>			
UPC Number	634878507134				

### VESA COMPLIANT & UNIVERSAL MOUNT PATTERN

Horizontal - 200, 250, 300, 350, 400, 450, 500, 550, 600, 650, 700, 750, 800, 850, 900mm  
 Vertical - 100, 200, 300, 350, 400mm  
 Display Mounting - M4, M5, M6, M8 Screws

Includes Microsoft Surface Hub 2 Mounting adapter (CA/MAC4) VESA 350mm x 350mm

### WALL FASTENING

Fasteners not included, select based on type of wall. Be sure wall structure is sufficient to handle load. Accommodates 5/16 inch (8 mm) fasteners.

### ELECTRICAL INFORMATION

Input: 90V - 240V ~, 48 Hz - 63HZ  
 Duty Cycle: 10% Max 2min / 18min

### CABLE MANAGER

Expandable Wire Loom: 1" Diameter (25mm) x 29" (1m)

### POWER CABLE

IEC - Type Class 2, 2-prong  
 USA Included: (PN 400-590)

Available:

EU (PN 400-591)  
 UK (PN 400-592)



FPS1W/GG  
E479586



© 2020 Microsoft. Microsoft, the Microsoft logo, Microsoft Surface, Surface, and the Microsoft Surface logo are trademarks of the Microsoft group of companies. All other trademarks are the property of their respective owners.

