

# TAA-COMPLIANT F-SERIES CAT5E SNAGLESS SHIELDED (STP) NETWORK CABLE

Meets stringent TAA compliant requirements and is approved for use in United States government projects and facilities

This Snagless Shielded Cat5e network cable is designed for network adapters, hubs, switches, routers, servers and more. Constructed with premium, made-in-the-USA copper cabling, its aluminum foil shield helps prevent RFI and EMI from affecting data transmission over the cable, making it an ideal solution for noisy environments. The molded boot provides extra strain relief and durability.



C2G43425

## FEATURES

- TAA-compliant
- Constructed with high quality, made in the USA raw cable for consistent, reliable performance
- Snagless RJ45 connector design protects clips from being easily snapped off—great for applications with high insertion cycles
- Standard RJ45 connectors—Al foil shield, 100% coverage
- 50-micron gold-plated contacts improve signal integrity
- Meets or exceeds all ANSI/TIA-568.2-D Category 5e industry standards for supporting a wide variety of applications, including 1000BASE-T (1 Gigabit Ethernet)
- Available in lengths up to 25 feet (7.6 m)
- Lifetime warranty

# TAA-COMPLIANT F-SERIES CAT5E SNAGLESS SHIELDED (STP) NETWORK CABLE

---

## PART NUMBERS

LENGTH	GRAY	BLUE	BLACK
<b>3ft (0.9m)</b>	C2G43425	C2G43431	C2G43437
<b>5ft (1.5m)</b>	C2G43426	C2G43432	C2G43438
<b>7ft (2.1m)</b>	C2G43427	C2G43433	C2G43439
<b>10ft (3m)</b>	C2G43428	C2G43434	C2G43440
<b>15ft (4.6m)</b>	C2G43429	C2G43435	C2G43441
<b>25ft (7.6m)</b>	C2G43430	C2G43436	C2G43442

# TAA-COMPLIANT F-SERIES CAT5E SNAGLESS SHIELDED (STP) NETWORK CABLE

		C2G43425-442
ELECTRICAL SPECIFICATIONS	Conductor DC Resistance	42.6Ω/1000' (maximum)
	Impedance	100 +/- 15 Ω
	Capacitance	13.5pf/ft @ 1MHz
	Voltage Rating	300V (maximum)
	Propagation Delay	534 + 36/√f ns/100m
	Delay Skew	<25ns/100m
PHYSICAL SPECIFICATIONS	Wiring Scheme	T568B
	Operating Temperature Range	-4°F to 167°F (-20°C to 75°C)
	Approvals	CE; RoHS; UKCA
	Standards	Meets ANSI/TIA-568.2-D and ISO/IEC 11801-1 electrical performance
	Warranty	Lifetime
	Package Type	Polybag
CONDUCTOR	Conductor Gauge	26AWG
	Insulation	HDPE: .010in nominal wall thickness
	Twist Pair	Blue, White/Blue, Orange, White/Orange, Green, White/Green, Brown, White/Brown
	Shield	AL Foil Shield, 100% Coverage
CONNECTORS	Connector	RJ45 (8P8C)
	Connector Type	Snagless
	Gender	Male
	Contacts	Gold Plated 50μ
	Hood	Molded PVC
OVERALL CABLE	Jacket	PVC
	Jacket Rating	CMR
	OD	5.6mm



# TAA-COMPLIANT F-SERIES CAT5E SNAGLESS SHIELDED (STP) NETWORK CABLE

## SPECIFICATIONS

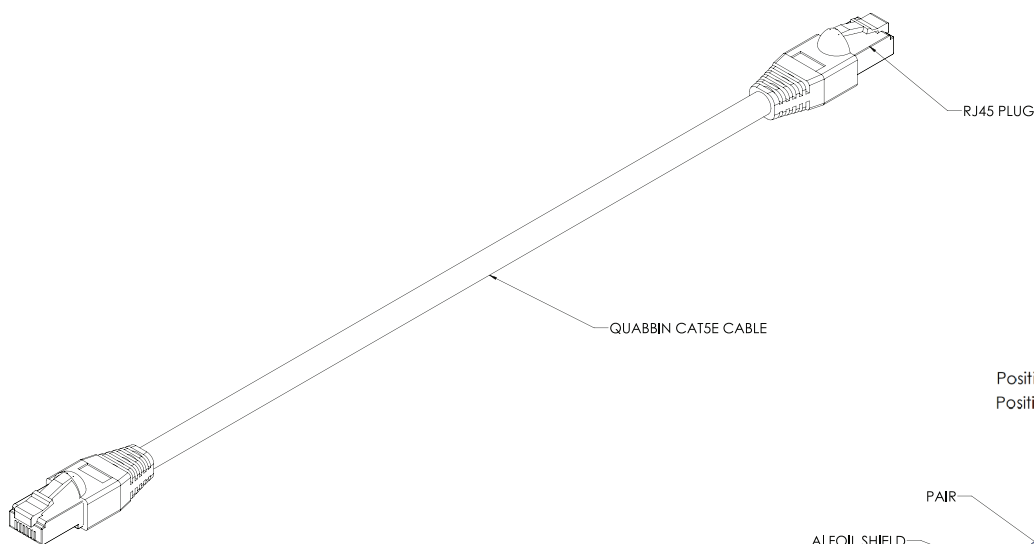
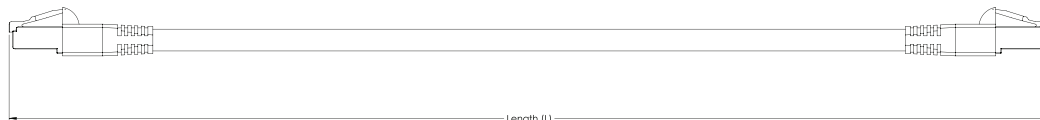

WIRE MAP T568B		
8P8C PIN#	WIRE COLOR	8P8C PIN#
1	WHT/ORG	1
2	ORG	2
3	WHT/GRN	3
4	BLU	4
5	WHT/BLU	5
6	GRN	6
7	WHT/BRN	7
8	BRN	8

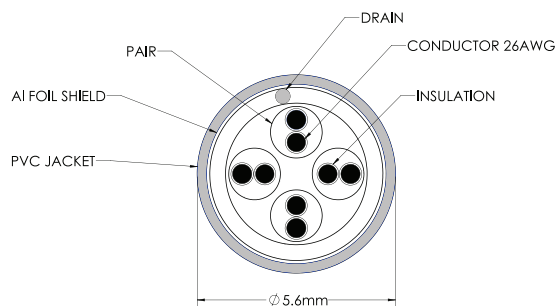
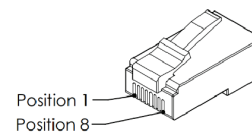

### LEGRAND | AV COMMERCIAL BRANDS

C2G | Chief | Da-Lite | Luxul | Middle Atlantic | Vaddio | Wiremold

#### SIMPLIFIED CONNECTIVITY

USA 800.506.9607 | [legrandav.com](http://legrandav.com) | [customer-service@c2g.com](mailto:customer-service@c2g.com)

EMEA +31 495 580 840 | [legrandav.com](http://legrandav.com) | [c2g.emea@av.legrand.com](mailto:c2g.emea@av.legrand.com)

©2024 Legrand AV Inc. 240127 Rev A 3/24 C2G is a registered trademark of Legrand AV Inc. All other brand names or marks are used for identification purposes and are trademarks of their respective owners. All patents are protected under existing designations. Other patents pending.