

50CAS is a set of x4 50mm (2in) casters. x2 are locking meant to be placed on the user side and the other x2 are non-locking. 50CAS comes with 8mm threaded studs. The threaded side screws into the furniture and the opposite side is designed to lock in with the casters. 50CAS is compatible with select furniture only.

Standard Features

- x2 locking 50mm casters
- x2 non-locking 50mm casters
- x4 8mm threaded studs

Compatibility

- LEL023 Height Adjustable Ergonomic Lectern
- LEL021 Height Adjustable ADA Lectern

Specifications

Model: 50CAS
Width: 2.16"
Depth: 2.77"
Height: 2.15"

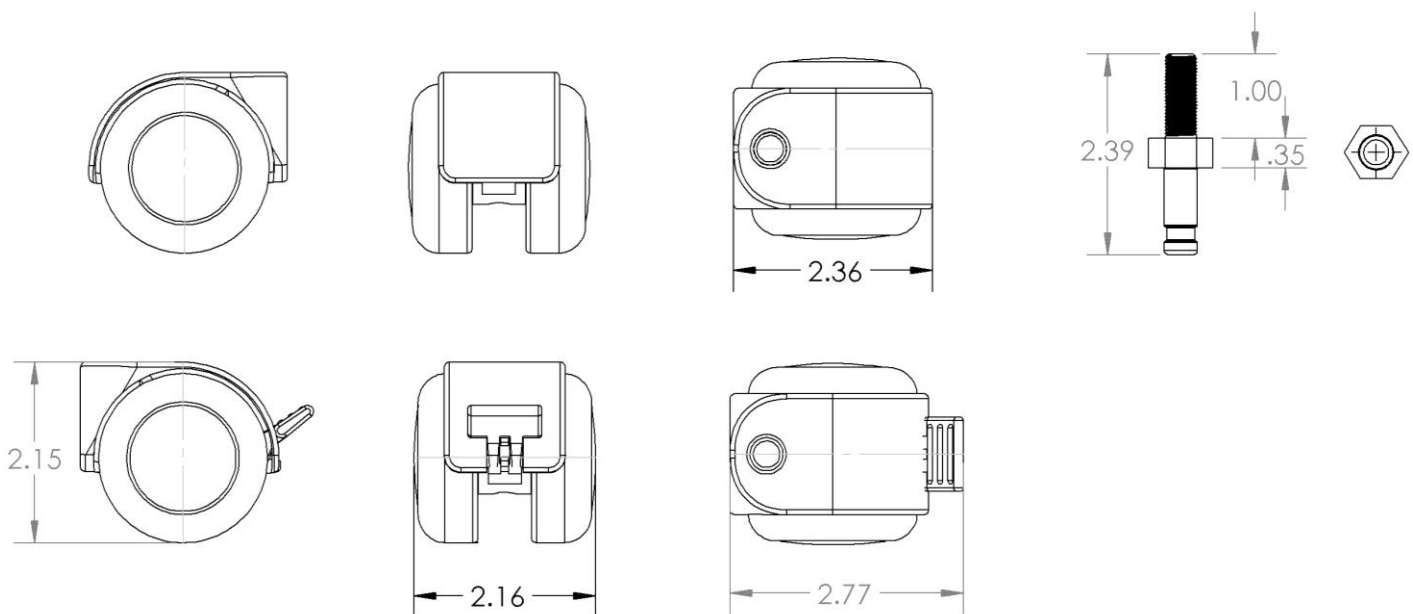

The information contained in this drawing is the sole property of Audio Visual Furniture International. Any reproduction in part or as a whole without the written permission of Audio Visual Furniture International is prohibited. We can build or modify stock configurations to suit customer specifications. Please contact us to discuss how this service can help meet your needs. Some quantity restrictions may apply. Specification subject to change without notice. Computers, cameras, monitors, etc. are shown to illustrate product usage and are not included unless otherwise noted.