



OWNER'S MANUAL

Stand For LG LED Screen

Please read this manual carefully before install & operating your set and retain it for future reference.

ST-136H Stand Installation

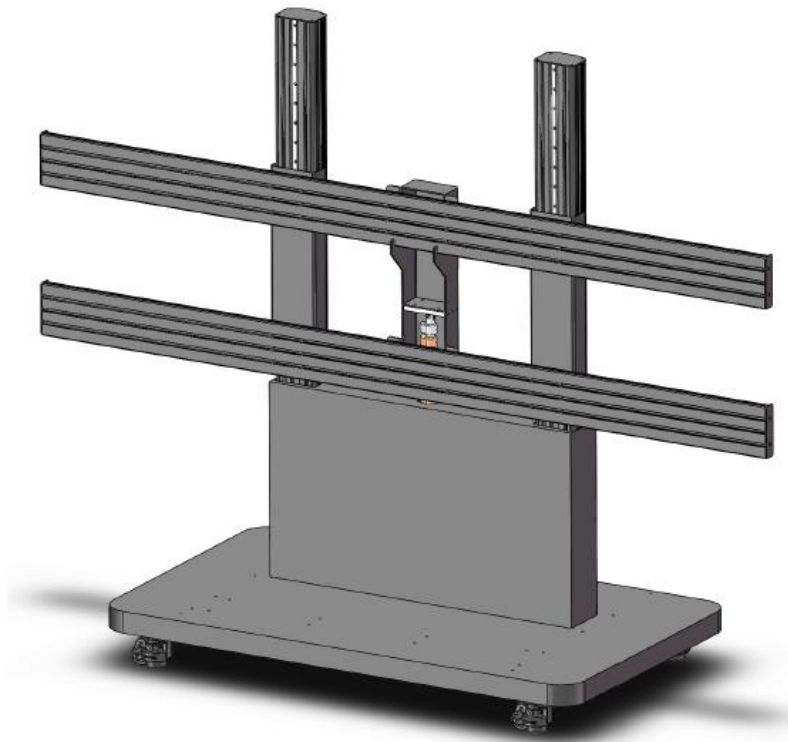

www.lg.com

Copyright © 2024 LG Electronics Inc. All Rights Reserved

Technical Data

Model Name	ST-136H
Material	Aluminum, Steel
Surface Finish	Powder Coating (Matte Black)
Recommended Screen Size	136 inch
Allowable Loads	200kg (Maximum)
Height Level	0~500mm
Voltage	100~240v
Certification	CB,ETL,KC,S-Mark,RoHS2.0,REACH
Stand Dimension (W x D x H)	2448 x 930 x 1920mm (MIN) 2448 x 930 x 2420mm(MAX)
Caster Size (Diameter)	63mm
Wooden Case Dimension (W x D x H)	2250 x 1450 x 540 mm
Weight (Net/Gross)	117/214±5kg

Caution: This model (ST-136H) is a stand intended for use only with LG Electronics Inc. LED Video Display AIO 136" model only. Use with other equipment may result in instability causing injury.

Please move the stand when the casters are unlocked and the stand is at the lowest setting mode.

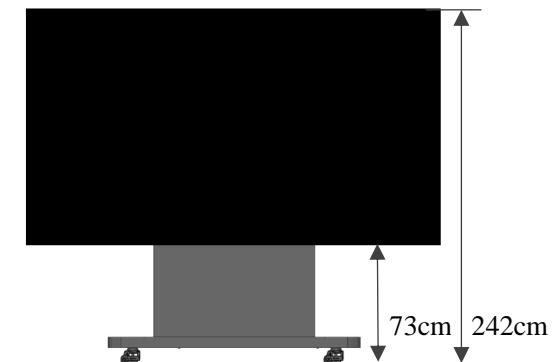
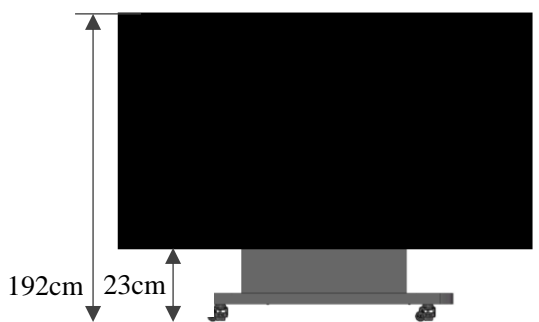
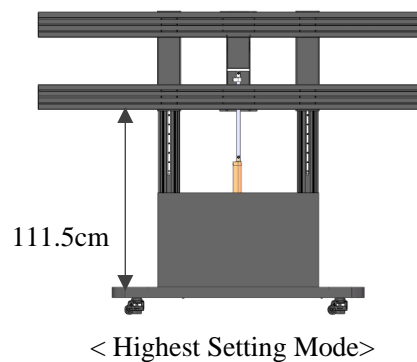
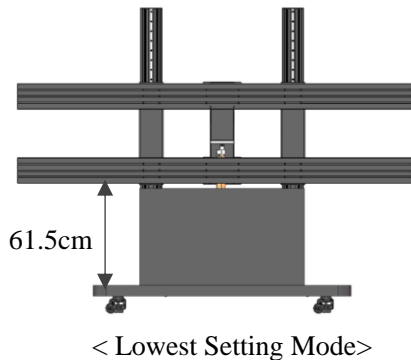

Packing List

Item	Description	Photo	Qty.
1	Stand Base		1
2	Left Vertical Support Column		1
3	Right Vertical Support Column		1
4	Horizontal Support Beam		2
5	Steel Tube		1
6	Linear Actuator		1
7	Rear Plate		1
8	Front Plate		1
9	Mounting Plate		4
10	Washer		16
11	M8X22mm Screw		24

12	M6X20mm Screw		4
13	M6X40mm Screw		36
14	M10X45mm Flat Head Screw With Nut		1
15	M4X10mm Flat Head Screw		4
16	M3X8mm Flat Head Screw		12
17	M10X20mm Flat Head Screw		8
18	M4X20mm Flat Head Screw		9
19	8mm Hex Key		1
20	M10 Socket		1
21	5mm Hex Key		1
22	Handset		1
23	Regulation Book		1

Note: The following tools may be used during the installation, such as screwdriver. Please use the tools provided with the panel.

1	Screwdriver		1
---	-------------	------------------------------------------------------------------------------------	---

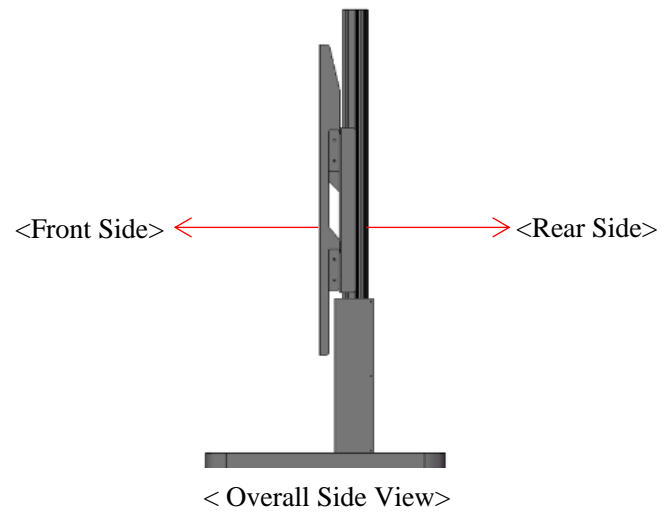

Assemble the stand

Step1. Install the vertical support column to the stand base.

Note: The slider block is facing front ←

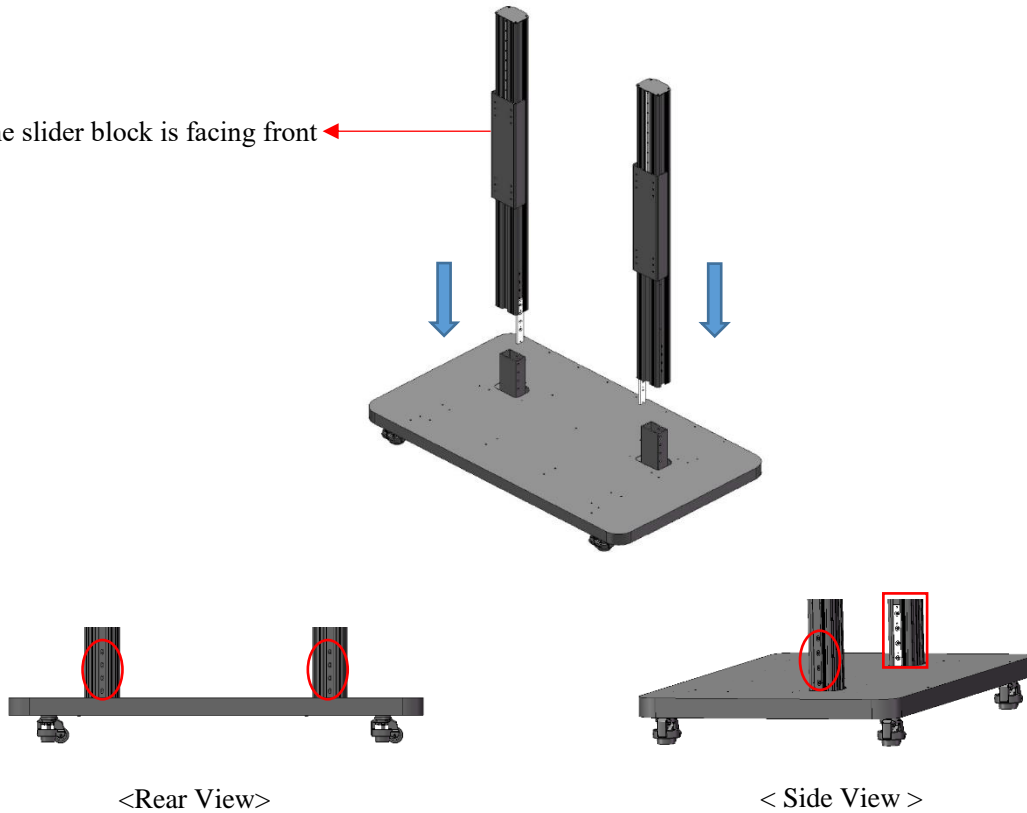

Use 8pcs M8X22 screws (Item 11) marked in square, use 16pcs M8X22 screws (Item 11) with 16pcs washer (Item 10) marked in circle to install the Item 2 and Item 3 on the stand base (Item 1).

Step2. Install the steel tube to the vertical support column.

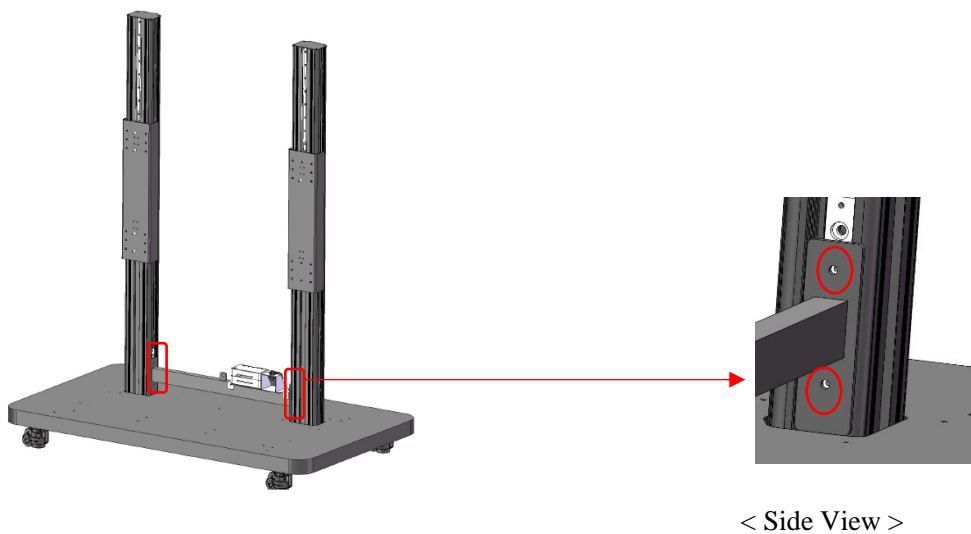

Use 4pcs M6X20 screws (Item 12) to install the Item 5 on the vertical support column (Item 2&3).

Step3. Loosen the screws and remove the gaskets of the vertical support column.

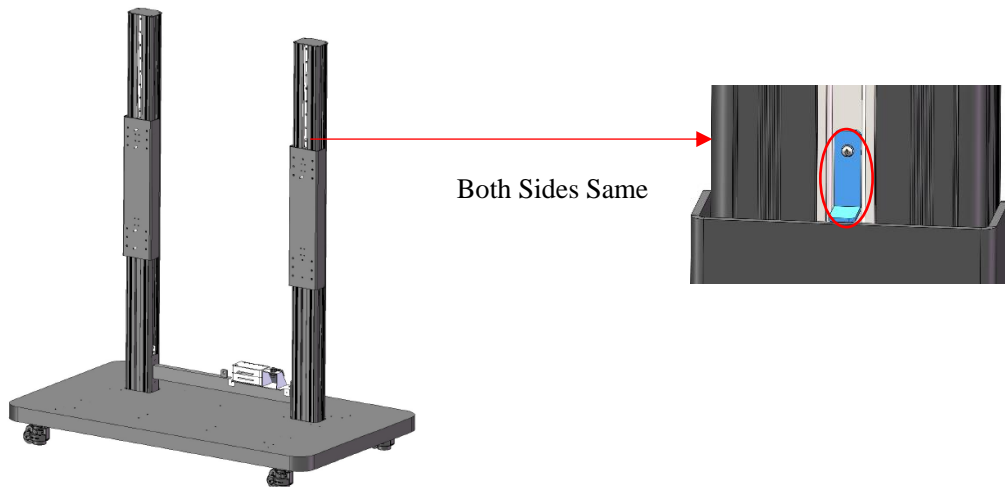

Loosen the screws marked in circle, and remove the gaskets.

Step4. Install the horizontal support beam to the vertical support column.

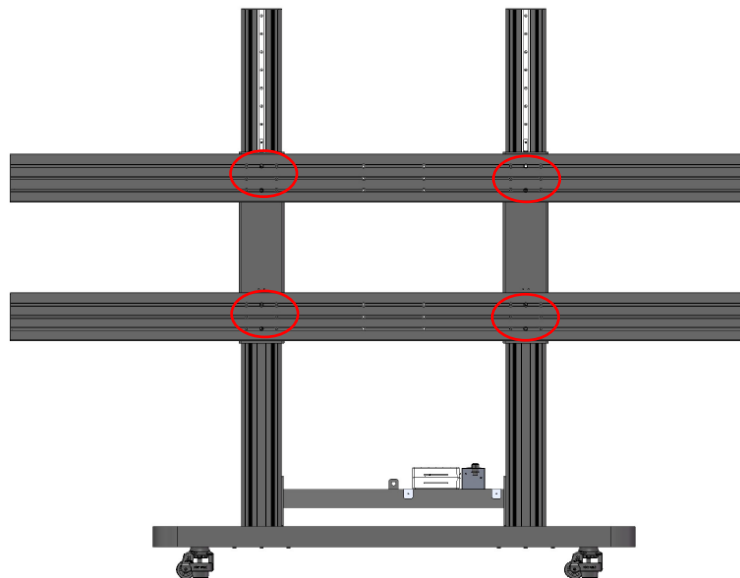

Use 24pcs M6X40 screws (Item13) to install the Item 4.

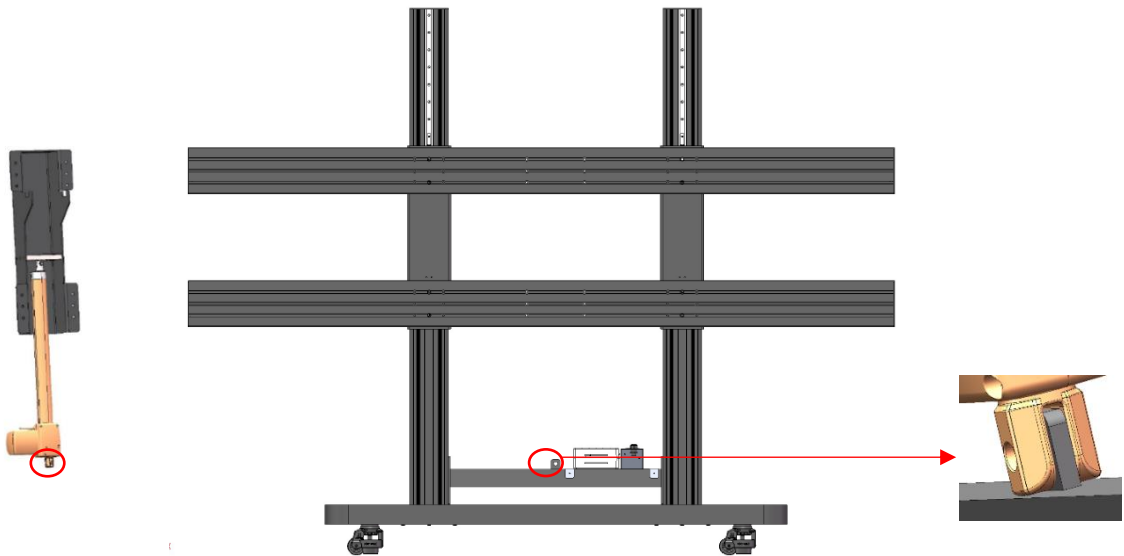
Step5. Install the linear actuator to the stand main body.

Align the 2 holes in red circle, and use 1pcs M10X45 (Item14) flat head screw with nut to connect Item5, Item6 marked in circle.

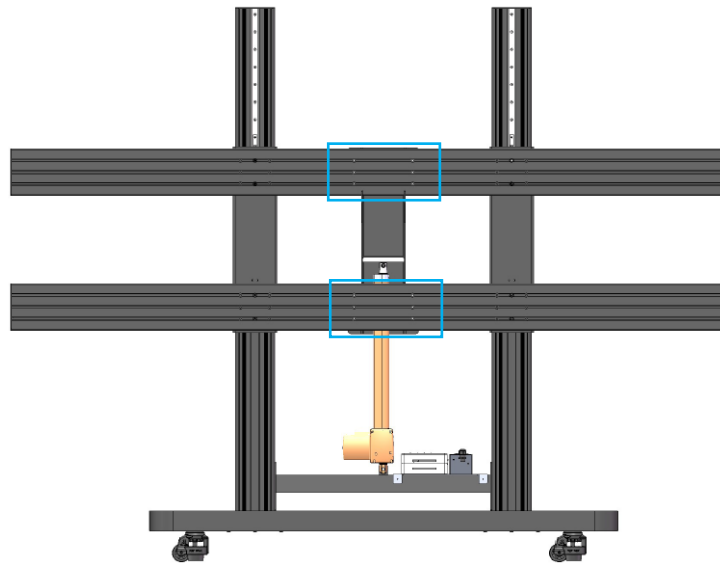

Use 12pcs M6X40 (Item13) screws to connect Item4, Item6 marked in square.

Step6. Install the rear plate.

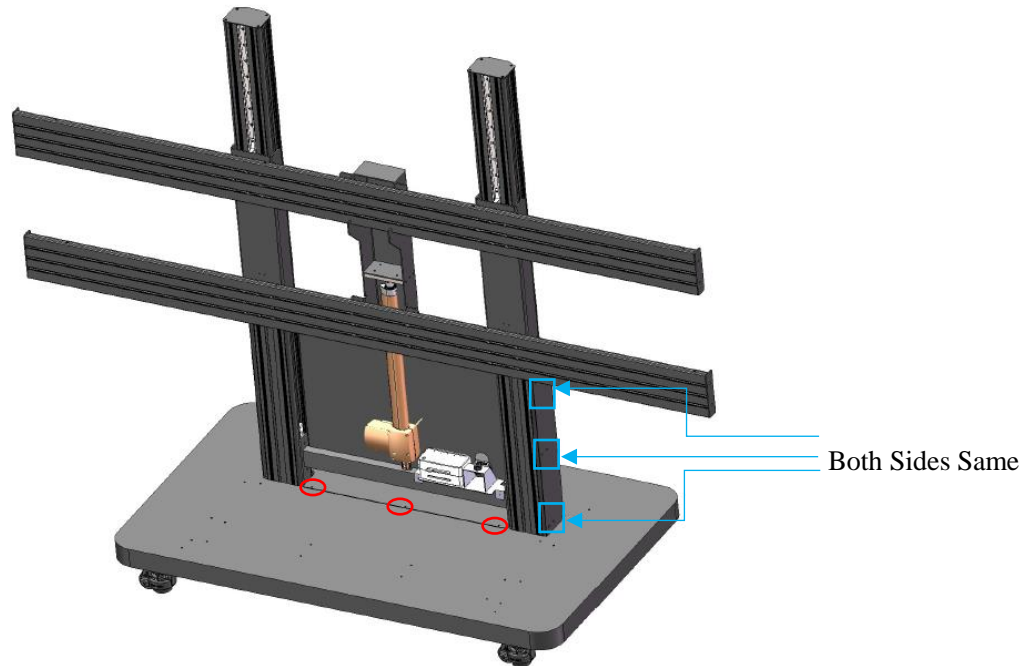

Use 3pcs M4X20 (Item18) flat head screws to connect Item1, Item7 marked in circle, and use 12pcs M3X8 (Item16) flat head screws to connect Item2, Item3, Item7 marked in square.

Step7. Connect the cable routing.

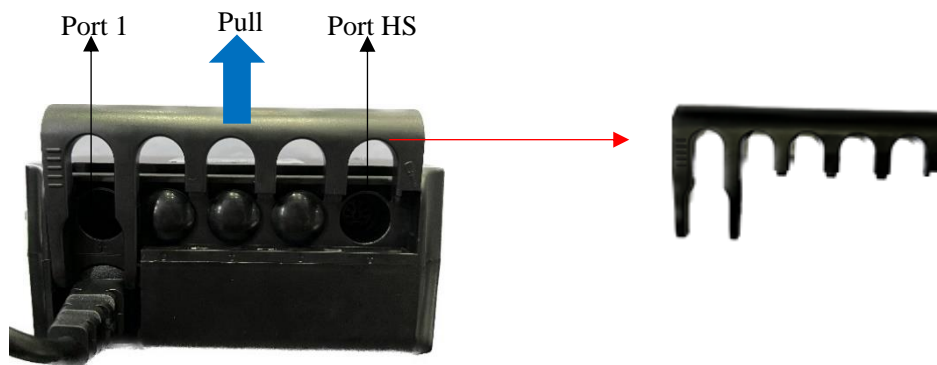

Step7-A. Connect the linear actuator cable.

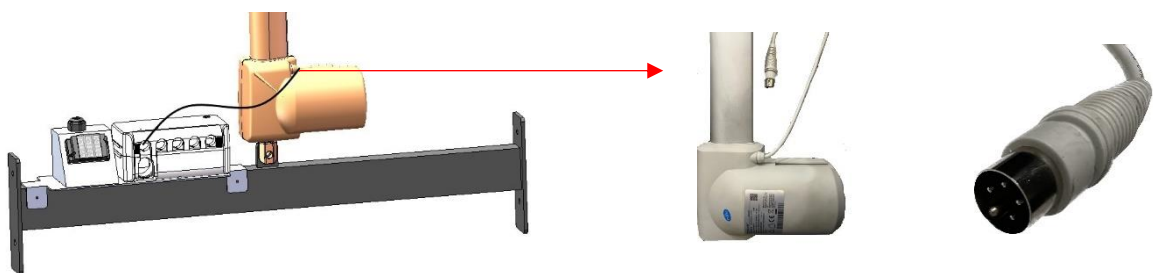

Before connecting the linear actuator cable, pull the controller cover, and then connect the linear actuator cable to the port 1.

Step7-B. Connect the handset cable and power cord.

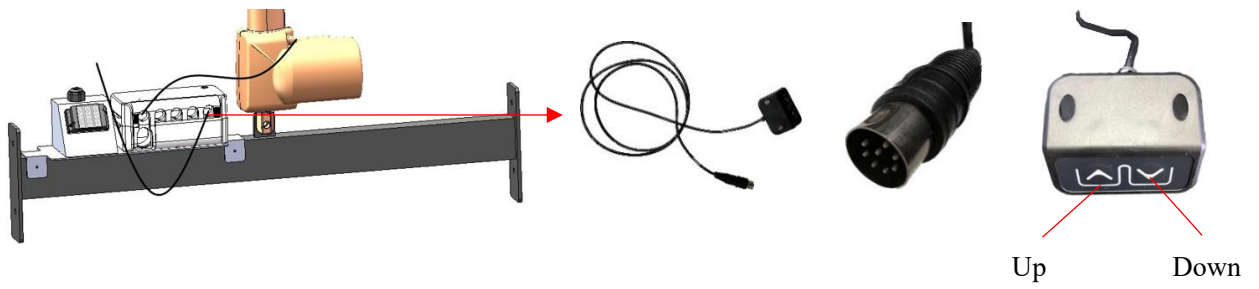

Before connecting the handset (Item 22) cable, pull the controller cover, pass the handset cable through the hole from the outside to the inside, and then connect the handset cable to the port HS.

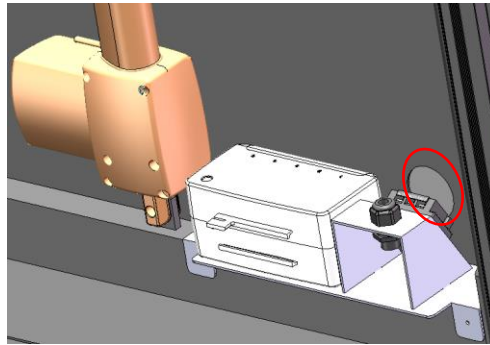
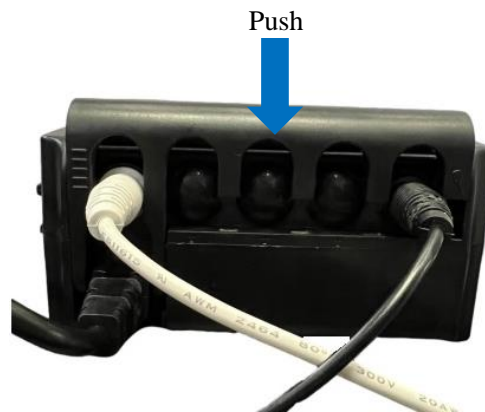

Pass the power cord cross the hole marked in circle.

Step8. Install the front plate.

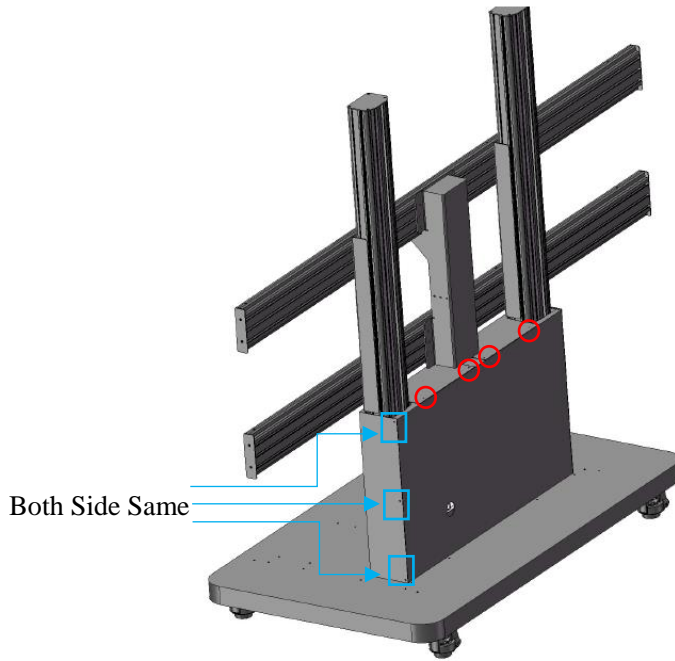

Use 4pcs M4X10 (Item15) flat head screws to connect Item7, Item8 marked in circle, and use 6pcs M4X20 (Item18) flat head screws to connect Item7, Item8 marked in square.

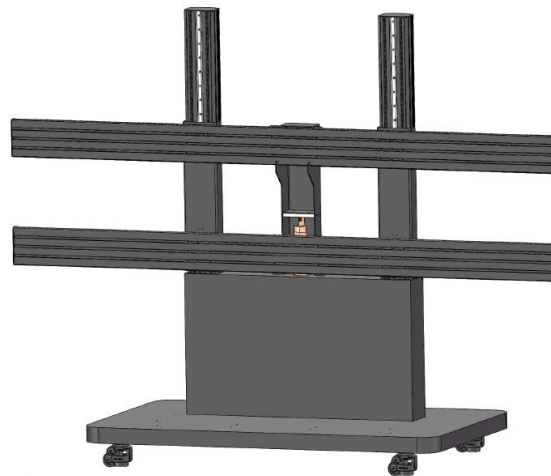

< Front View >

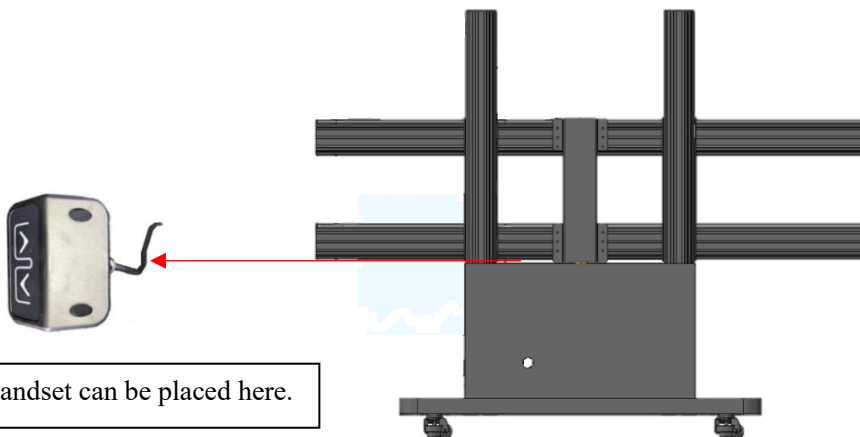

The handset can be placed here.

< Rear View >

Screen assembly

Step1. Install the mounting plate to the panel.

< Rear View >

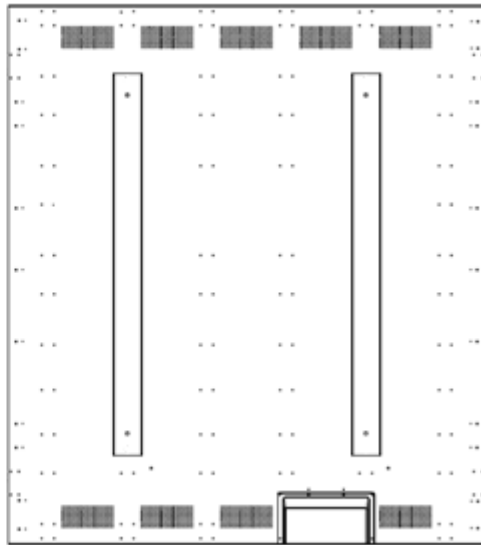
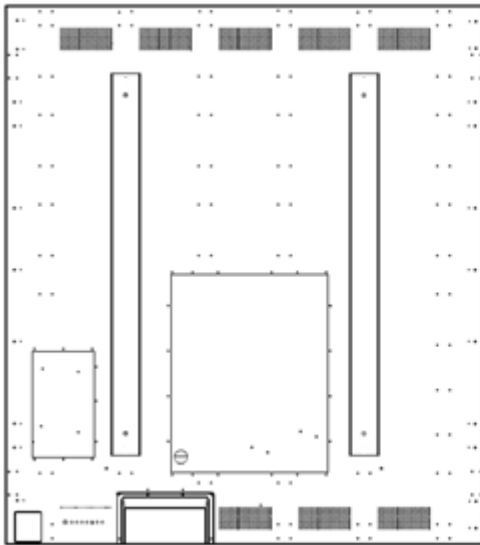
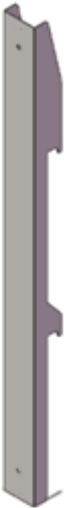
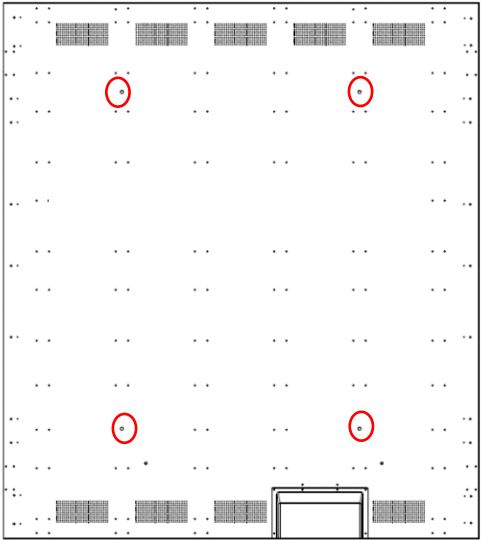
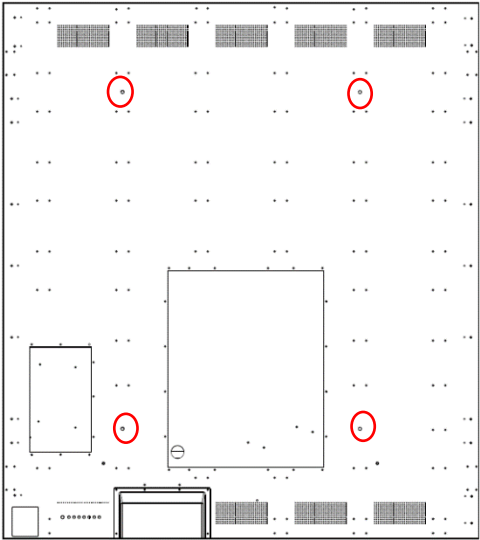

Use 8pcs M10X20 screws (Item17) to connect Item9 and panel.

Step2. Install the panel to the stand.

Note: Please install the left cabinet onto the stand first, and then install the right cabinet.

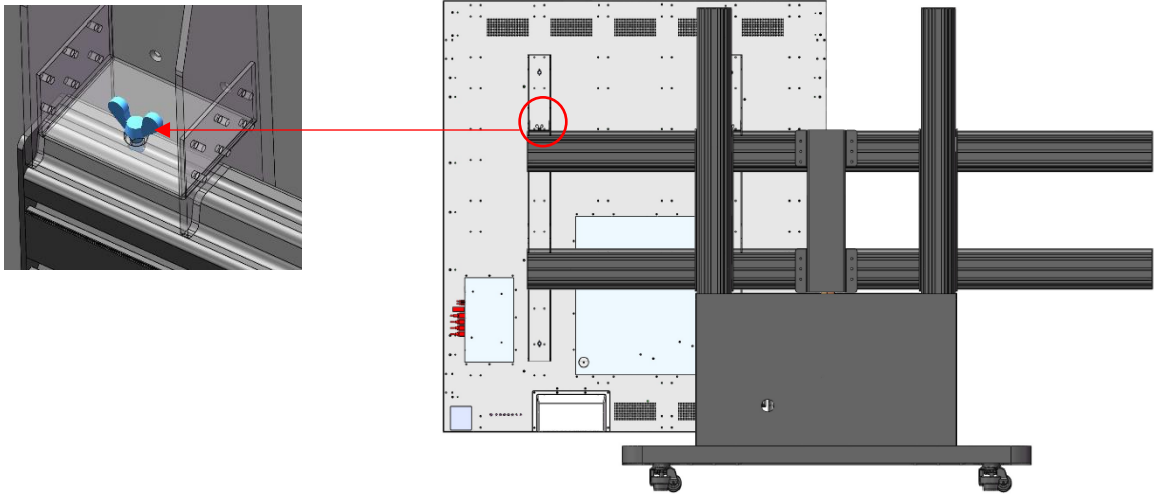

< Rear View >

After installing the left cabinet, loosen the screw marked in circle and make it downward to coincide with the gap of the horizontal support beam.

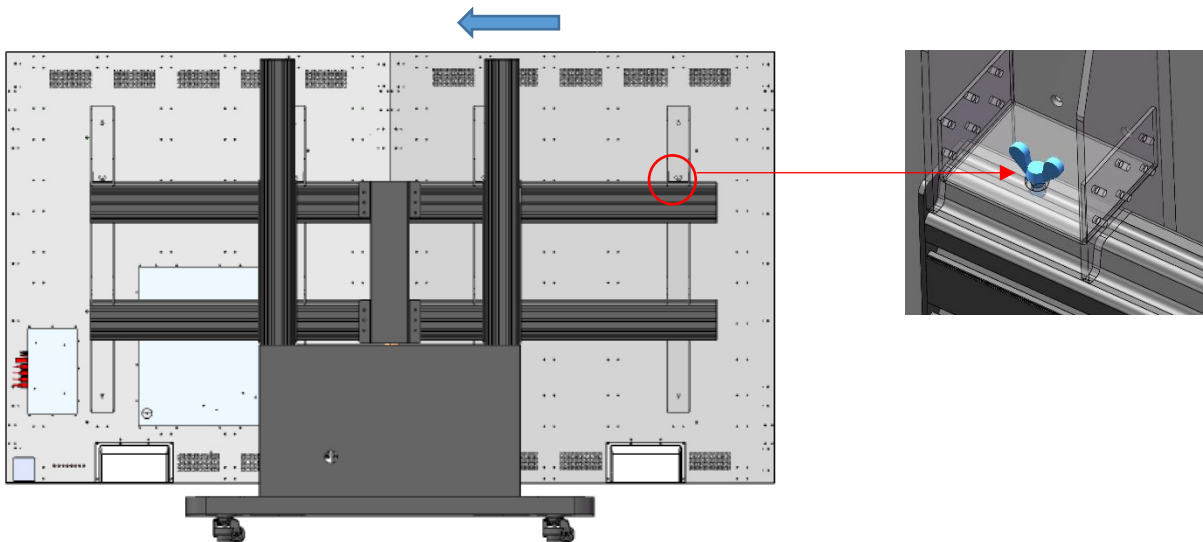

< Rear View >

After installing the right cabinet, loosen the screw marked in circle and make it downward to coincide with the gap of the horizontal support beam.

Leveling caster

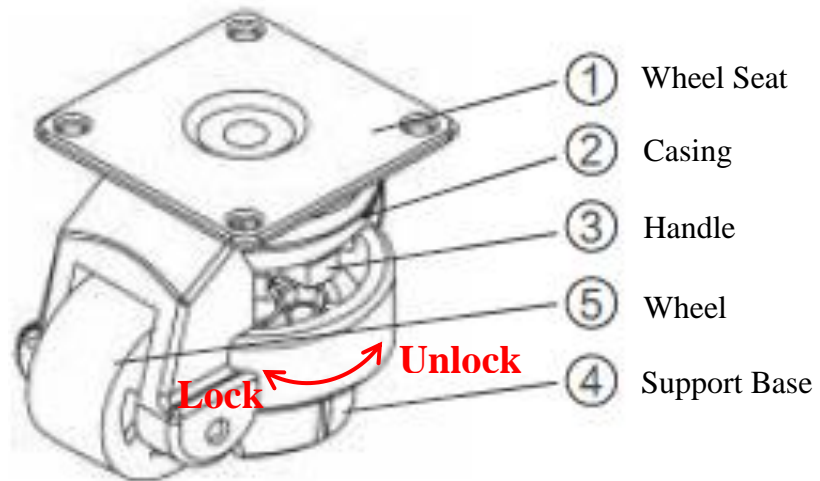

Note: 1. For safety, after completing the screen installation, lock the casters to prevent the stand from moving.
2. Rotate the handle clockwise to lock, and counterclockwise to unlock.



The model and serial number of the product are located on the back and on one side of the product. Record them below in case you ever need service.

MODEL

SERIAL

NO.

Temporary noise is normal when powering ON or OFF this device.