

DS-LEDUNV Models



SEAMLESS KITTED

Universal dvLED Mounting System

FOR LATCHING DISPLAYS*

The Peerless-AV® SEAMLESS Kitted Series Universal dvLED Mounting System features a slim, space-saving and versatile design. The DS-LEDUNV is adaptable and supports latching dvLED displays. This kitted solution is also designed and built to your display specifications and then scaled to your video wall configuration. The display adaptors and mount frame provide x, y and z axis adjustments to overcome uneven walls and to assure the video wall remains flat. The lightweight aluminum frame quickly attaches to the wall with assistance from the installer-friendly wall template, and the quick-connect clamps allow installers to easily attach the displays to the mount frame. Quickly and easily build the perfect dvLED video wall for a corporate lobby, retail display, sportsbook, concert hall, casino, and much more with Peerless-AV's Universal dvLED Mounting System.



- Open architecture provides ease of cable management
- Optional Trim Kit Accessory is compatible with most displays (DS-LEDTK Models)

*Please contact a Peerless-AV® Sales Representative for the current list of compatible latching dvLED display models.

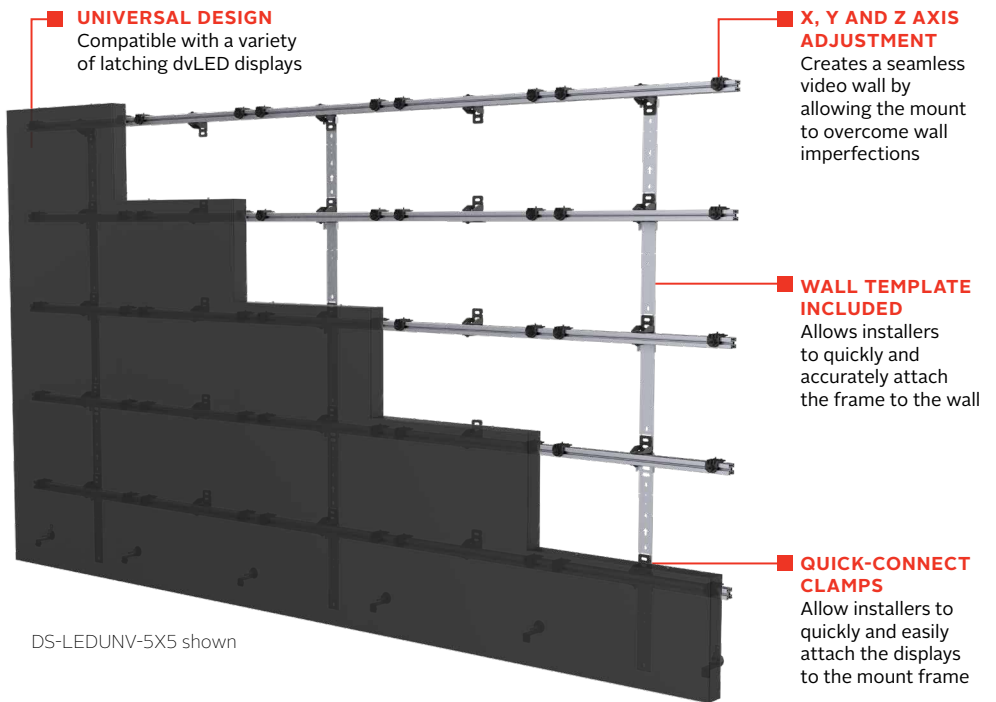

DS-LEDUNV-5X5 shown



SEAMLESS by Peerless-AV® - dvLED Video Wall Integration Program offers:



**EXPERT
ENGINEERING & DESIGN**



**CUSTOM
PROJECT MANAGERS**

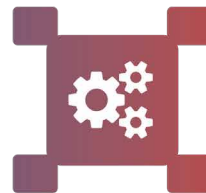

**FULL INSTALLATION
SERVICES**

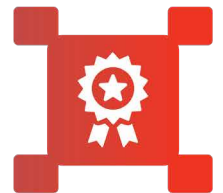

**SEAMLESS dvLED
MOUNTING SYSTEMS**

Model Numbers

WARRANTY: 5 Years

DS-LEDUNV Models SEAMLESS Kitted Series Universal dvLED Mounting System for Latching Displays*

Product Specifications

*Please contact a Peerless-AV® Sales Representative for the current list of compatible latching dvLED display models.

	DIMENSIONS (W x H x D)	PRODUCT WEIGHT	LOAD CAPACITY	FINISH	AVAILABLE COLORS
DS-LEDUNV Models	Based on Final Configuration 2.82"-3.49" (72-89mm) Mount Depth Range	Based on Final Configuration	52lb (23.6kg) per display	Powder Coat & Clear Anodized Finish	Black Brackets, Silver Extrusions & Template

Package Specifications

	PACKAGE SIZE (W x H x D)	PACKAGE SHIP WEIGHT	PACKAGE CONTENTS	UNITS IN PACKAGE
DS-LEDUNV Models	Based on Final Configuration 10' Extrusion: 121.00" x 15.75" x 7.00" (3073 x 400 x 178mm) 8' Extrusion: 97.00" x 15.75" x 7.00" (2464 x 400 x 178mm) 6' Extrusion: 73.00" x 15.75" x 7.00" (1854 x 400 x 178mm)	Based on Final Configuration	Wall Template, Wall Plate, Extrusion, Adaptor Clamps, Standoff and Mounting Hardware	1

Accessories

DS-LEDTK Models: Universal Trim Kit for dvLED Video Walls 3.9" to 6.3" (99-160mm) Deep

All dimensions = inch (mm)

Components:

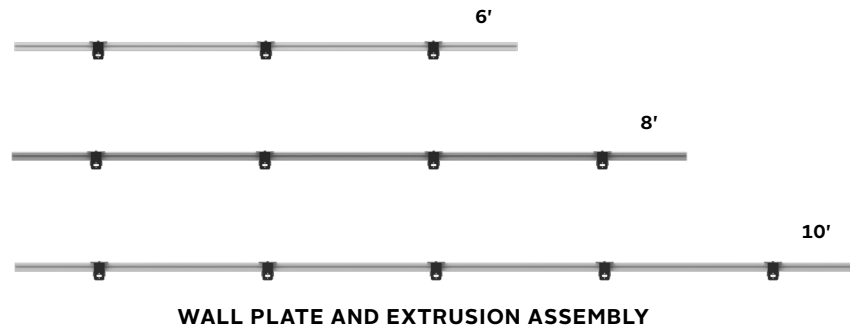

WALL PLATE AND EXTRUSION ASSEMBLY



ADAPTOR



STANDOFF



TEMPLATE

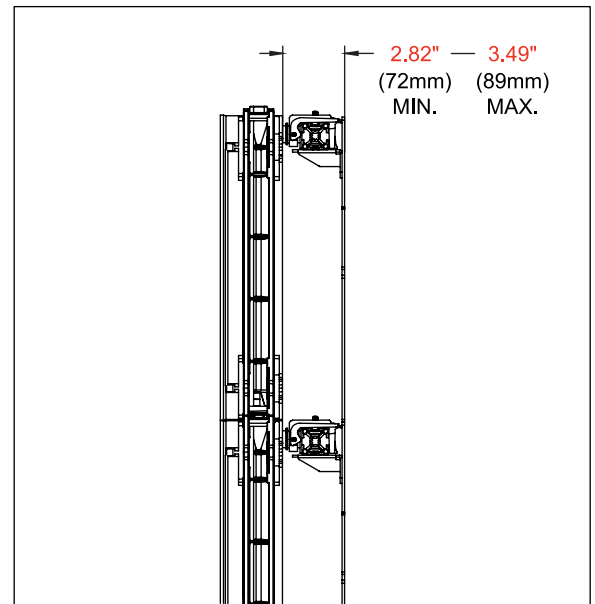

SIDE VIEW WITH dvLED DISPLAY

Architect Specifications

The SEAMLESS Kitted Series Universal dvLED Mounting System shall be a Peerless-AV DS-LEDUNV and shall be located where indicated on the plans. Assembly and installation shall be done according to instructions provided by the manufacturer.

Visit peerless-av.com to see the complete line of AV solutions from Peerless-AV, including outdoor displays, kiosks, display mounts, projector mounts, carts/stands, and a full assortment of accessories.

Peerless-AV
2300 White Oak Circle
Aurora, IL 60502
USA
(800) 865-2112
(630) 375-5100

Peerless-AV EMEA
Unit 2 Curo Park
Frogmore, St. Albans
Hertfordshire, AL2 2DD
United Kingdom
+44 (0) 1923 200 100

Peerless-AV B.V.
Papendorpseweg 75
3528 BJ Utrecht
The Netherlands
+31 (0) 70 770 8037

Peerless-AV Latin America
Av. de las Industrias 413
Parque Industrial Escobedo
General Escobedo, N.L.,
México, 66062
+52 (81) 8384-8300

peerless-AV®
Driving Technology Through Innovation

LIT-1912 rev.8