



This versatile multimedia cart model **103324** has been designed with functionality as its main characteristic. The top surface is large enough to accommodate up to 32" monitors or for your computer screens, visual presenters or laptops.

Standard Features

- Folding side shelf
- Retractable keyboard shelf
- 12U rack mount (10-32 screws)
- Front and rear locking doors
- Premium locking casters
- Available in black laminate finish

Options

- **MM1232** Monitor and camera mount (12" - 32")
- **C900S** 15" - 24" Adjustable monitor arm
- **C900D** Adjustable dual monitor arm. Holds monitors up to 22" horizontal width each
- **FAN** Quiet cooling fan
- **PB** Six outlet power bar with 10 ft. cord
- **9031** Vented metal shelf
- **9041** Sliding shelf
- **9052** Sliding drawer
- **9107** Lacing bar (19" long)
- **CASTER** 6" Metal caster with gray non-marking tire (2 locking)
- **LEV4AX4** 4x Levelers for non-mobile applications
- **CUSTOM CUTOUT** Cutouts for electronics or other items specified by the customer



Shown with optional **C900S** (Sold separately)

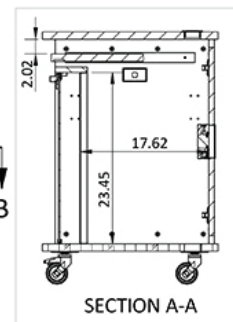
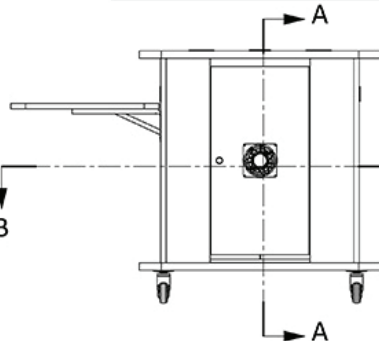
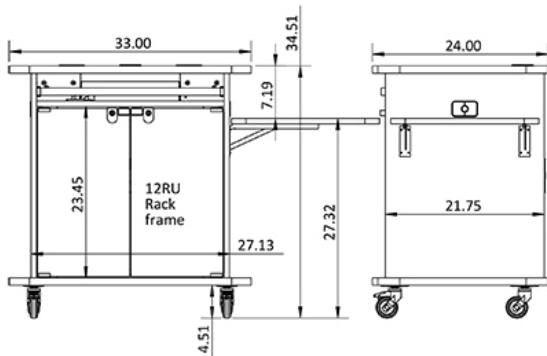
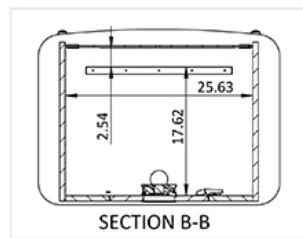
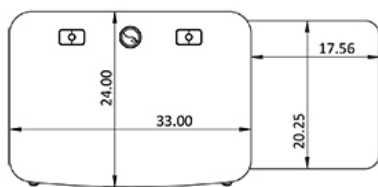

Specifications

Model: 103324
Width: 33"
Depth: 24"
Height: 34-3/4"

Finish



The information contained in this drawing is the sole property of Audio Visual Furniture International. Any reproduction in part or as a whole without the written permission of Audio Visual Furniture International is prohibited. We can build or modify stock configurations to suit customer specifications. Please contact us to discuss how this service can help meet your needs. Some quantity restrictions may apply. Specification subject to change without notice. Computers, cameras, monitors, etc. are shown to illustrate product usage and are not included unless otherwise noted.