

SLIM-PROFILE DESKTOP MIC BOOM ARM

GFWMICBCBM0500

GATOR FRAMEWORKS

COPYRIGHT GATOR CO. - ALL RIGHTS RESERVED - 9/2022 - REV.A

PRODUCT DIMENSIONS

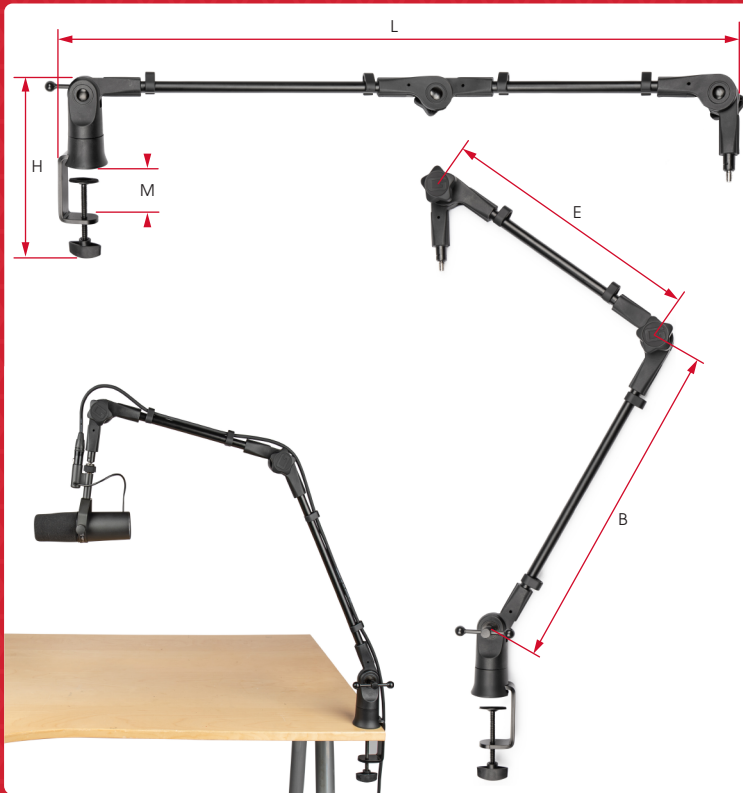

FEATURES



// Conveniently Clamps to Most Desk Edges up to 2.4" (61mm) Thick



// Articulating Arm with Locking Joints: Holds 2.20 lbs. at Max Reach of 32.75"



// Included Cable Clips Keep Wires Neat and Organized

PRODUCT DIMENSIONS

Overall (L x W x H)	35.0" x 2.8" x 9.0 (889 x 71 x 229 mm)
Boom / Extension (B / E)	18.3" / 14.4" (465 / 365 mm)
Max Boom Reach	32.7" (830 mm)
Max Clamp Width (M)	2.4" (61 mm)
Material	Cast & Extruded Metal, Plastic
Color/Finish	Black Powder Coat
Product Weight	2.6 lbs (1.2 kg)

Gator Frameworks is dedicated to producing the highest quality stands and accessories. We back up that commitment with a 3 year Warranty on any manufacturing defects in material and workmanship. This warranty applies to the original owner and requires proof of purchase. Our warranty entitles the original owner repair or replacement of the product, or replacement with a comparable product of similar value and condition at our discretion. This warranty is limited to Gator Frameworks products only and excludes loss of personal property, loss of use, accidental damage, misuse, or normal wear and tear.

— For Full Warranty Information Visit —
www.gatorframeworks.com

